



# "Manual on Best Practices in Indian Thermal Power Generating Units"



**Confederation of Indian Industry**  
CII – Sohrabji Godrej Green Business Centre



## Contents

<b>S No</b>		<b>Page No</b>
	Executive Summary	<b>1</b>
	How to use this Manual	<b>5</b>
1.0	Introduction to the Project	<b>7</b>
2.0	Background of Indian Power Sector	<b>15</b>
3.0	Best Performance Parameters of Indian Power Plants	<b>19</b>
4.0	Best Practices in Indian Power Plants	<b>31</b>
4.1	Performance Improvement – Heat Rate & Auxiliary Power Consumption	<b>33</b>
4.2	Performance Improvement – Reliability & Availability	<b>57</b>
4.3	Operation & Maintenance	<b>63</b>
4.4	Environment Improvement	<b>111</b>
4.5	Miscellaneous Projects	<b>127</b>
5.0	Mission to International Power Plants – Imbibing next technologies	<b>147</b>
6.0	Action plan & Conclusion	<b>159</b>
	Annexure	<b>162</b>



## EXECUTIVE SUMMARY

- ❖ Power sector is one of the fastest growing sectors in India, which essentially supports the economic growth. The power sector needs to grow at the rate of 12% to maintain the present GDP growth of 8%.\*
- ❖ Presently the energy deficit is about 8.3% and the power shortage during the peak period is about 12.5%.\*
- ❖ The total installed capacity of the power generating units is about 1,24,310 MW. Thermal power generating units contribute 66.4% of total installed capacity. The average plant load factor of the thermal power generating units is 74.8%.\*  
(\* Source: Ministry of power website – [www.powermin.nic.in](http://www.powermin.nic.in))
- ❖ In the present scenario, apart from capacity augmentation, there is an immense need to improve the performance of the individual thermal power generating units. The performance improvement of individual thermal power generating units will help in achieving
  - Increased power generation and there by reducing the demand supply gap
  - Reduction in power generation cost and thereby improving the competitiveness of Indian industry
  - Reduction in Green house gas emissions and Global warming
- ❖ Hence, to catalyze and facilitate performance improvement of power generating units CII-Godrej Green Business Centre has initiated the project “**Make Indian power plants world Class**”.
- ❖ The objectives of this project are to:
  - Identify the best operating parameters for coal and Gas based thermal power plants
  - Identify and collate the best practices in Indian power plants which can be suitably fine tuned and replicated in various power plants to move towards achieving the benchmarking figures.

## ***Manual on best practices in Indian Thermal Power Generating Units***

---

- Identify the state of the art technologies adopted in international power plants, which will help the Indian power plants to reach the world class standards.
- ❖ CII-Godrej GBC has taken the responsibility of overall execution of the project under the able guidance of advisory group chaired by **Mr P K Kukde, Executive Director, Tata Power Company Limited.**
- ❖ A working group was formed to take up the actual execution of the project, under the leadership of **Mr P K Basu, Executive Director, CESC Limited.**
- ❖ An action plan was formulated for achieving the objectives of this project. The action plan includes the following:
  - Setting up target for performance improvement for the individual power generating units.
    - Set and achieve voluntary target of 3-5% improvement per year for each parameter.
  - Initiating a mass movement for performance improvement in thermal power generating units.
  - Developing model world class power plants to demonstrate the benefits to other power generating units
- ❖ Development of this edition of the manual on “Best practices in Thermal Power Generating units” is one of the first steps in the direction of making Indian power plants world class.
- ❖ The manual contains the following:
  - Best operating parameters of coal based thermal power plants and gas turbine & combined cycle power plants
  - Collated best practices adopted and performance improvement projects implemented in various Indian thermal power generating units
  - Collated state of the art technologies adopted in international power generating units.

**EXECUTIVE SUMMARY**

---

- ❖ It is a fact that the Indian power industry has power generating units with various capacities, different fuel firing and vintages. However, these identified best operating parameters will provide a broad guideline for improving the performance.
- ❖ The best practices and the performance improvement projects highlighted in the report need to be suitably fine tuned to meet the requirements of individual power plants.
- ❖ CII-Godrej GBC will disseminate the information amongst the Indian power plants. CII-Godrej GBC will render all possible assistance in carrying out detailed energy audits, identification of performance improvement projects to achieve the targets.
- ❖ The objective of the project will be fulfilled only if the mass movement for performance improvement of power generating units picks up and all the Indian power generating units start achieving the world class standards.





## HOW TO USE THIS MANUAL

- ❖ The spirit behind this manual is to act as a catalyst to initiate activities in Indian power generating units towards continuously improving the performance of individual units and achieving the world class standards.
- ❖ To set a clear goal for improving the performance and moving towards the world class standards, the best operating parameters have been evolved for Coal based thermal power plants and Gas turbine power plants.
- ❖ The best operating parameters have been evolved for coal based power plants of capacity more than 125 MW and Gas turbine power plants of capacity more than 100 MW.
- ❖ These parameters per se do not serve any purpose, unless those parameters have been utilized as target / guide line parameters for performance improvement.
- ❖ Hence, in addition to the best operating parameters, the best practices adopted in various power plants, which have helped significantly to improve their performance have also been included in this report.
- ❖ These best practices may be considered for implementation, after suitably fine tuning to meet the requirements of individual plants for further improvement.
- ❖ Apart from the best practices from Indian power plants, the details about the state of the art technologies from the international power generating units also have been included.
- ❖ Suitable latest technologies may be considered for implementation in the existing / future power plants for achieving the world class standards. Further investigation needs to be done for the suitability of these technologies for Indian conditions.
- ❖ The collated best operating parameters and the best practices identified from various power plants need not necessarily be the ultimate solution. It is possible to achieve even better figures and develop better operation and maintenance practices, collation of which can then come out as the next edition of this manual for dissemination to all power plants.
- ❖ Therefore, the Indian power generation industry should view this manual positively and utilize this opportunity to improve the performance and move towards the world class standards.



# CHAPTER - 1

## MAKE INDIAN POWER PLANTS WORLD CLASS

### 1.1 Introduction

In India, the gap between the energy demand and supply is very significant. The energy deficit during April 2005 to February 2006 is about 8.3% and the power shortage during peak period is about 12.5%\*.

The present installed capacity of power generating units is about 1, 24,310 MW. Thermal power generating units accounts for about 66.4 % of the total installed capacity. The overall plant load factor of the thermal power generating units is about 74.8 %\*.

(\* Source: Ministry of power website – [www.powermin.nic.in](http://www.powermin.nic.in) )

Hence to meet the demand supply gap, apart from augmenting the capacity, there is an immense need to improve the performance of the existing power generating units.

The performance improvement of the existing power generating units can be taken up in the following areas:

- Availability
- Reliability
- Output
- Efficiency
- Cost
- Environment protection

To catalyze and facilitate the performance improvement of Indian power plants, the project “**Make Indian Power plants World Class**” has been undertaken by CII-Sohrabji Godrej Green Business Centre (CII-Godrej GBC).

### 1.2 Make Indian Power plants World Class

CII-Godrej GBC is promoting the concept of “**world class energy efficiency**” in Indian industry. To achieve world class standards, CII – Godrej GBC has adopted a unique strategy of creating sector wise leadership. The Power Sector is one amongst them.

## ***Manual on best practices in Indian Thermal Power Generating Units***

---

Towards this initiative, CII – Godrej GBC institutionalized an annual event “**Power Plant Summit**” since 2002. The theme of the power plant summit is “**Make Indian Power Plants World Class**”. The objectives of the summit are to facilitate sharing of the information about the latest trends and technologies, best operating and maintenance practices etc.

The origin of this project can be traced to the “**Power Plant Summit-2004**”. During the power plant summit 2004, the entire fraternity of power industry had felt that in addition to sharing of information in events and conferences, there is a need for concrete action plan and continuous movement for making Indian power plants world class. In this direction

- ❖ Formation of **Advisory Group** - an advisory group was formed for guiding all the activities of the project, under the leadership of **Mr P K Kukde, Executive Director, The Tata Power Company Limited.**

**The objective of the advisory group is to facilitate Indian power plants to reach the world class standards by the year 2008.**

- ❖ **Working Group** – a working group was formed for the actual execution of the project, under the able leadership of **Mr P K Basu, Executive Director, CESC Limited.**

The advisory group and working group have representatives from various power plants from all over India, power plant consultancies, equipment suppliers, service providers etc.

Members of Advisory group and working group are as below.

- Andhra Pradesh Power Generation Corporation Limited
- Bharat Heavy Electricals Limited
- Central Electricity Authority
- CESC Limited
- Electric Power Research Institute
- Gujarat Industrial Power Corporation Ltd

---

**MAKE INDIAN POWER PLANTS WORLD CLASS**

---

- GMR Energy Limited
  - Gujarat State Electricity Corporation Limited
  - Jindal Thermal Power Corporation Limited
  - Karnataka Thermal Power Corporation Limited
  - Neyveli Lignite Corporation Limited
  - National Thermal Power Corporation Limited
  - Punjab State Electricity Board
  - Reliance Energy Limited
  - STEAG Encotec
  - The Tata Power Company Limited
  - Tata Consulting Engineers
  - West Bengal Power Development Corporation Limited
- ❖ **Action plan** - After a series of meetings and deliberations, a concrete action plan was formulated for moving towards making Indian power plants world class. The action plan includes
1. Identifying the best operating parameters from the high performing thermal power plants
  2. Collation of the best operating and maintenance practices by visiting the high performing national and international thermal power generating units
  3. Continuous sharing of the best practices amongst the Indian power plants through various forums such as Power plant summit
  4. Ultimately helping the Indian thermal power generating units to achieve the world class standards.
- This exercise helps in
- Understanding the present performance of existing power generating units
  - Setting clear targets for performance improvement

## ***Manual on best practices in Indian Thermal Power Generating Units***

---

The collation of the best operating and maintenance practices from various high performing thermal power generating units will help the power generating units to move towards the benchmarking figures.

Imbibing the next practices, the latest trends and technologies from the international power plants will help the Indian power generating units to achieve the world class standards.

### **1.3 Activities Performed**

The activities performed during the entire project are as follows:

#### **1.3.1 Data collection**

A comprehensive questionnaire was developed for collecting details about the coal based thermal power station and the gas turbine and combined cycle power plants.

The questionnaires are given as annexure – 1 & 2 for reference.

#### **1.3.2 Good governance visit**

Four Good governance teams have been formed from the working group. The good governance teams visited the high performing Indian thermal power plants to identify the best practices.

The good governance team details and the units visited are given below.

**MAKE INDIAN POWER PLANTS WORLD CLASS**

<b>Good Governance Team Details and the plants visited</b>		
<b>Teams</b>	<b>Team members</b>	<b>Plants visited</b>
<b>Team - A</b>	<b>Mr Dhanajay Deshpande</b> – Reliance Energy Limited <b>Mr J R Gakhar,</b> Kota Thermal Power station <b>Mr Neelesh Neema,</b> GMR Energy Limited	<ol style="list-style-type: none"> <li>1. CESC Limited, Kolkata</li> <li>2. Gujarat State Electricity Corpn Ltd (GSECL), Utran</li> <li>3. GSECL, Ukai</li> <li>4. GSECL, Gandhi Nagar</li> <li>5. GSECL, Wanakbori</li> </ol>
<b>Team – B</b>	<b>Mr U V Ladsaongikar,</b> The Tata power Company Ltd <b>Mr D P Roy Choudhry,</b> The West Bengal Power Development Corporation <b>Mr Suhas Patil,</b> Reliance Energy Limited	<ol style="list-style-type: none"> <li>1. Jindal Thermal Power Corp. Ltd, Thoranagallu</li> <li>2. GMR Energy Limited, Mangalore</li> <li>3. National Thermal Power Corporation Ltd, Simhadri</li> <li>4. National Thermal Power Corporation Ltd, Ramagundam</li> <li>5. Bakreshwar Thermal Power Station, WBPDC</li> </ol>
<b>Team – C</b>	<b>Mr S Arumugam,</b> National Thermal Power Corporation Ltd <b>Mr Rabi Chowdhry,</b> CESC Ltd <b>Mr B Prabhakaran,</b> GMR Energy Ltd	<ol style="list-style-type: none"> <li>1. Raichur Thermal Power Station, Karnataka Power Corporation Ltd</li> <li>2. Reliance Energy Limited, Dahanu</li> <li>3. The Tata Power Company Limited, Trombay</li> </ol>
<b>Team - D</b>	<b>Mr P Raheja,</b> Steag Encotec <b>Mr Lakshmipathy,</b> Tata Consulting Engineers <b>Mr Sethurao,</b> Jindal Thermal Power station	<ol style="list-style-type: none"> <li>1. National Thermal power Corporation Ltd, Faridabad</li> <li>2. Punjab State Electricity Board, GGSTP</li> <li>3. Kota Thermal Power Station, RUVNL</li> </ol>

### ***Manual on best practices in Indian Thermal Power Generating Units***

---

The identified best practices have been compiled as part of this report. Adoption of these best practices, by suitably fine tuning to the requirement of the individual power plants may help in improving the performance of the power plant and moving towards the benchmarking parameters.

A comprehensive methodology was developed for rating the participant power plant based on the good governance parameters. The visiting team members have rated the power plants based on their observations for individual parameters.

#### **1.3.3 Mission to International power plants**

To identify the state of the art technologies, which could be adopted in India mission was taken to the latest power generating units in Australia, Germany and Japan.

The details of team visited the international power generating units are given below.

<b>Teams</b>	<b>Team members</b>	<b>Country</b>	<b>Plants visited</b>
<b>Team - A</b>	<b>Mr P K Majumdar,</b> Reliance Energy Limited  <b>Mr S Vidyanand,</b> TCE Consulting Engineers Ltd	Germany	<ul style="list-style-type: none"> <li>● RWE power – Niederaussem power plant</li> <li>● STEAG Voerde</li> <li>● Mainz Wiesbaden Combined cycle power plant</li> <li>● E ON Engineering</li> </ul>
<b>Team - B</b>	<b>Mr P K Basu,</b> CESC Limited  <b>Mr Verkey,</b> Jindal Thermal Power Corporation Ltd	Australia  Japan	<ul style="list-style-type: none"> <li>● CS Energy Limited, Swanbank power station</li> <li>● Tarong Energy</li> <li>● Kawagoe Plant of Chubu Electric</li> <li>● Hekinan Plant of Chubu Electric</li> </ul>

#### **1.3.4 Report**

Subsequent to the data collection and good governance visit to various power plants all over India, the data have all been compiled, collated, analyzed and the best operating parameters for coal based and gas turbine power plants have been collated.



---

***MAKE INDIAN POWER PLANTS WORLD CLASS***

---

The report includes the following:

- ❖ The best operating parameters for
  - Coal based thermal power plants
  - Gas turbine and Combined cycle power plants
- ❖ The Best practices from the Indian power plants which will help achieving the benchmarking
- ❖ Information about the state of the art technologies adopted in international power generating units.



## CHAPTER - 2

# BACKGROUND OF INDIAN THERMAL POWER PLANTS

### 2.1 Present power scenario

Power sector is one of the core industrial sectors, which plays a very vital role in overall economic growth of the country. The power sector needs to grow at the rate of atleast 12% to maintain the present GDP growth of about 8%.

As per the Ministry of Power report, during the year 2004 – 2005, the per capita consumption of electricity in India is 606 kWh/year. The per capita consumption of electricity expected to grow to 1000 kWh / year by the year 2012.

To meet the per capita consumption of 1000 kWh / year by the year 2012 the capacity augmentation requirement is about 1, 00,000 MW.

The present installed capacity of the power generating units is 1, 24,311 MW. The break up of installed capacity of power generating units is given below.

<b>Fuel</b>	<b>Capacity in MW</b>	<b>%</b>
Total thermal	82,508	66.4
Coal	68,643	55.2
Gas	12,663	10.2
Oil	1,202	1.0
Hydro	32,335	26
Nuclear	3,310	2.7
Renewable	6,158	4.9
<b>Total</b>	<b>1,24,311</b>	<b>100</b>

(Source: Ministry of Power)

Presently there is a significant gap between the power demand and supply. The energy deficit is about 8.3% and the power shortage during the peak demand is about 12.5%. The details of power situation from April 2005 to February 2006 are as below.

---

**Manual on best practices in Indian Thermal Power Generating Units**

---

<b>Description</b>	<b>Demand</b>	<b>Met</b>	<b>Surplus / deficit</b>
Energy (MU)	575,384	527,539	- 8.3 %
Peak Demand	92, 968	81,370	- 12.5 %

(Source: Ministry of Power)

## 2.2 Performance of thermal power generating units

The installed capacity of the thermal power generating units contributes for about 66.4% of the total installed capacity. The performance of the thermal power generating units, therefore play a significant role in meeting the demand supply gap.

Based on the Central Electricity Authority annual report for the year 2004-2005, the few of the average performance parameters of the Indian thermal power plants for the last 4 years are as below.

<b>Description</b>	<b>2001-02</b>	<b>2002-03</b>	<b>2003-04</b>	<b>2004-05</b>
Forced outage %	10.56	9.87	9.48	8.84
Planned maintenance %	9.52	8.30	8.59	8.23
Operating availability factor %	79.91	81.83	81.93	82.93
Plant load factor	69.97	72.34	72.96	74.82
Specific fuel oil consumption (ml/kWh)	2.70	0.68	2.37	1.37
Auxiliary power consumption (%)	8.72	8.53	9.91	8.57

(Source: Annual report – Performance review of thermal power stations 2004- 2005)

The above performance figures are based on the data collected from about 375 thermal power units with a cumulative capacity of about 64,646 MW.

As can be seen from the above table, Significant efforts have been taken by the individual power generating units to improve the plant load factor. The average plant load factor has increased from 69% to 74.8% in the past four years.

The average capacity augmentation last decade is about 4.4%, whereas increase in power generation is about 7%. This clearly indicates the continuous improvement of the plant load factor of the power generating units.

---

**BACKGROUND OF INDIAN THERMAL POWER PLANTS**

---

**2.3 Potential for further performance improvement**

For the benchmarking exercise, data from 19 thermal power generating units have been collected. The comparison of

For the benchmarking exercise, data from 19 thermal power generating units have been collected. The comparison of the best figures in each parameter achieved by any Indian power plant over three years (2001 – 2004) with such figures for 2004 – 2005 of relatively high performing India power plants are given below.

<b>Description</b>	<b>Avg parameters of a Best performing unit</b>	<b>Average parameters of all Indian thermal power plants</b>
Forced outage %	4.44	8.84
Planned maintenance %	1.03	8.23
Operating availability factor %	93.6	82.93
Plant load factor	93.18	74.82
Specific fuel oil consumption	1.20	1.37
Auxiliary power consumption	7.53 %	8.57

The table clearly indicates that there is a significant gap between the average performance figures of Indian thermal power generating units and the figures of the best performing power generating unit. This clearly indicates that the potential for performance improvement is tremendous in Indian thermal power generating units.

If the availability factor of the existing thermal power generating units is increased by 10%, from the present level the capacity addition requirement will come down by 12,000 MW. This will reduce the investment requirement of about Rs 48,000 Crores.



## **CHAPTER - 3**

# **BEST PERFORMANCE PARAMETERS OF INDIAN POWER PLANTS**

### **3.1 Selection of power plants**

The Indian power sector has power plants with various capacities, variety of fuel firing, different technologies and vintages.

For the purpose of comparison and collation the power plants have been broadly classified into two categories:

- Coal based thermal power plants
- Gas turbine and Combined cycle power plants

Thermal power plants having installed capacity of more than 125 MW and Gas turbine & combined cycle power plants having capacity of more than 100 MW have been considered for the benchmarking exercise.

### **3.2 Data collection from power plants**

A detailed questionnaire exclusively for coal based thermal power plants and Gas turbine power plants were developed for data collection.

The following broad areas have been considered for identifying the best performance parameters of coal based power plants.

- Availability / Reliability
- Efficiency
- Cost of power
- Impact on Environment
- Safety
- Resource Utilisation

For the gas turbine power plants the mean time between the minor inspections (MTBMI), HGP % above OEM recommendations and Deviation from the mean of tolerance band of temperature spread are also considered.

## ***Manual on best practices in Indian Thermal Power Generating Units***

---

***In the questionnaire, for each parameter based on the operating range vis-à-vis the design parameters / statutory requirement / the best possible operating range, indicative points are allocated. The total summation of maximum score possible for all parameters taken together is 100.***

The detailed questionnaires for Coal and gas turbine power plants are enclosed as annexure 1 & 2.

Filled in questionnaires were received from **19 power plants** from all over India.

- Coal based thermal power plants - 16 Nos
- Gas turbine power plants - 3 Nos

A comprehensive questionnaire and rating system was developed for rating the participant power plants based on the Good governance parameters.

The good governance team has rated the individual power plants, based on their observations & data collection, during their visit to the participant power plants.

The questionnaire and the rating system are given in Annexure - 4.

### **3.3 Data Analysis**

The data collected from all the coal based and gas turbine power plants have been collated. A **Q matrix** was developed based on the collated data. The Q matrix is given for reference.

The Q matrix has the details of indicative points for each parameter for all participant power plants.

Based on the good governance visits to the participant power plants and the data collected, the G matrix was developed. The **G matrix** is also given for the reference.



### 'Q Matrix' of participant Power Plants

Name of the Power Plant	A	B	C	D			E	F	G	
Description				1	2	3			1	2
	Coal	CCGT	Coal	Coal	Coal	Coal	Coal	Coal	Coal	CCGT
	2 x 250	240	7 x 210	3x210	4x210	4X210	7x210	2 x 250	500	180
Availability	8	10	12	2	9	33	23	34	22	23
Efficiency	3	2	3	11	13	10	6	15	15	15
Cost	1	1	3	0	3	0	10	5	10	10
MTBMI		1								5
HGP		0.5								3
Temperature spread		3								
Impact on Environvion	6	2	5	2.5	1	3.5	5	4	5	5
Effluent	3.4	5	1.8	1.4	1.4	1.8	3.1	1.3	4	4
Ash utilisation	3.48		0.14	0.5	5	2.7	2.8	0.05	2.5	
Safety	0.5	2	2	2	2	2	2	2	1.5	1.25
Resource Utilisation										
Manpower	0	1	0	0	0	0	0	0.25	0.5	1
Water Consumption	1	1	0	0	0	0	1	1	1	1
Grand Total	26.38	28.5	26.94	19.4	34.4	53	52.9	62.6	61.5	68.25

## 'Q Matrix' of participant Power Plants

Name of the Power Plant	H	I	J	K		L	M			N	O
Description				1	2		1	2	3		
	Coal	Coal	Coal	CCGT	Coal	CCGT	Coal	3X210	7X210	Coal	Coal
		2 x 250	3X200	432	3x500	135	4X210	4x210	4X210	2 x 130	2 x 500
Availability	3	25	23	17	18	5	0	0	5	42	22
Efficiency	3	3	1	7	0	15	1	1	1	6	6
Cost		0	10	10	10	1	5	0	1	3	10
MTBMI				5		1					
HGP				2		0.5					
Temperature spread				3		1					
Impact on Environviron	5.25	5.5	7	5	7	5	2	1	2	7	7
Effluent	0.9	2.6	3.2	5	3.2	3.6	0.5	3.1	3.3	4.6	5.6
Ash utilisation	1	2	*		*		4.17	3	1	2.91	5
Safety			2	4	2	2	1	1	1	2	2
Resourse Utilisation											
Manpower	0	0	0	2	0	0	0	0	0	1	0.75
Water Consumption	0.5	1	1	2	1	0	1	1	0	1	1
Grand Total	13.7	39.1	47.2	62	41.2	34.1	14.67	10.1	14.3	69.51	59.35

## 'G Matrix' of participant Power Plants

		A	B	C	E	F	G	H
		Coal	CCGT	Coal	Coal	Coal	Coal	Coal
		2 x 250	240	7 x 210	7x210	2 x 250	500	3x 210
<b>1.</b>	<b>Customer</b>							
	<b>Need</b>							
1.1	Customer service ( Trends & improvements for 3 to 5 years )	4	3	2	2	1	4	3
1.2	Customer service ( Trends & improvements for 3 to 5 years )	4	0	2	2	1	4	2
<b>2.</b>	<b>Employees</b>							
	<b>Description</b>							
2.1	Work Procedures	4	4	2	2	4	3	3
2.2	Protections	3	4	1	1	4	4	3
2.3	Occupational health hazard	4	4	1	1	3	4	3
2.4	Industrial Relationship	3	4	3	3	3	4	4
2.5	Increased Productivity achieved through motivated team work ( Expressed in terms of cost , Quality & time improvements ) Trends: 3 to 5 years	4	4	3	3	4	4	3
2.6	Manpower	-	4	2	2	2	2	3
2.7	Health & Safety ( Trends & improvements for 3 to 5 years )	3	4	2	2	3	4	4
<b>1</b>	<b>Customers</b>							
2.8	Health & Safety	2	3	3	3	4	4	3
2.9	Health & Safety	2	3	2	2	4	4	3

## 'G Matrix' of participant Power Plants

		A	B	C	E	F	G	H
		Coal 2 x 250	CCGT 240	Coal 7 x 210	Coal 7x210	Coal 2 x 250	Coal 500	Coal 3x 210
2.10	Satisfaction & Engagement ( Trends for 3 to 5 years )	2	3	2	2	3	4	-
2.11	Satisfaction & Engagement ( Trends for 3 to 5 years )	2	4	1	1	3	4	3
2.12	Satisfaction & Engagement ( Trends for 3 to 5 years )	-	2	3	3	4	4	2
2.13	Training & Development / .Job enrichment ( Trends for 3 to 5 years )	4	3	2	2	3	4	2
2.14	Training & Development / .Job enrichment ( Trends for 3 to 5 years )	4	3	1	1	3	4	3
2.15	Training & Development / .Job enrichment ( Trends for 3 to 5 years )	3	-	2	2	4	4	4
2.16	Rewards & recognition	3	2	2	2	4	4	3
2.17	Rewards & recognition	1	-	2	2	4	4	4
2.18	Effective /Two way communication	3	3	2	2	4	4	3
2.19	Effective /Two way communication	0	3	2	2	4	4	3
2.20	Code of conduct	0	3	-	-	-	-	3
2.21	Code of conduct	0	2	-	-	-	-	-
2.22	Employee participation	0	3	1	1	4	4	4
<b>3.</b>	<b>Society around</b>							
3.1	Hazard management systems	1	2	2	2	4	4	3
3.2	Accountability	2	-	2	2	4	4	2
3.3	Society	3	-	2	2	4	4	3

## 'G Matrix' of participant Power Plants

		A	B	C	E	F	G	H
		Coal 2 x 250	CCGT 240	Coal 7 x 210	Coal 7x210	Coal 2 x 250	Coal 500	Coal 3x 210
3.4	Community initiative	2	4	2	2	4	5	4
3.5	Community initiative	2	3	2	2	4	5	3
3.6	Sharing/Service through professional bodies representing power industry.	3	3	2	2	3	3	3
3.7	Sharing/Service through professional bodies representing power industry.	3	3	2	2	3	3	4
<b>4</b>	<b>Shareholders</b>							
4.1	Share Holders (or else those who have a stake in cos.)	-	-	-	-	-	3	-
4.2	Share Holders (or else those who have a stake in cos.)	-	-	-	-	-	3	-
<b>5.</b>	<b>Suppliers</b>							
5.1	Mutual Benefits through supplier partnership	-	-	-	-	3	3	2
5.2	Mutual Benefits through supplier partnership	-	-	-	-	3	3	-
<b>6.</b>	<b>Cost / Productivity / Quality</b>							
6.1	Cost Control	4	3	3	4	4	3	3
6.2	Cost Control	4	3	4	4	4	4	3
6.3	Increased productivity	4	4	3	3	4	3	2
6.4	Increased productivity	4	4	3	3	4	3	2
6.5	Increased productivity	4	4	3	3	4	4	3
6.6	Quality	4	4	1	1	4	4	2
	<b>Grand Total</b>	<b>95</b>	<b>105</b>	<b>74</b>	<b>75</b>	<b>129</b>	<b>146</b>	<b>107</b>

## 'G Matrix' of participant Power Plants

		J		L	M			N	O
		1	2	1	1	2	3		
		Coal	CCGT	CCGT	Coal	3X210	7X210	Coal	Coal
		3x200 & 3x500	432	135	4X210	4x210	4X210	2 x 130	2 x 500
<b>1.</b>	<b>Customer</b>								
	<b>Need</b>								
1.1	Customer service ( Trends & improvements for 3 to 5 years )		4				3	2	
1.2	Customer service ( Trends & improvements for 3 to 5 years )		1					2	
<b>2.</b>	<b>Employees</b>								
	<b>Description</b>								
2.1	Work Procedures	3	4	3	3	3	4	4	
2.2	Protections	3	4	3	3	3	4	4	
2.3	Occupational health hazard	3	4	3	3	2	4	2	
2.4	Industrial Relationship	3	4	2	2	2	4	4	
2.5	Increased Productivity achieved through motivated team work ( Expressed in terms of cost , Quality & time improvements ) Trends: 3 to 5 years	3	4	3	3	2	3	3	
2.6	Manpower	4	5				5	3	
2.7	Health & Safety ( Trends & improvements for 3 to 5 years )	4	5		3	3	3	4	
<b>1</b>	<b>Customers</b>								
2.8	Health & Safety	4	5	2	3	2	4	5	
2.9	Health & Safety	4	5	2	3	2	4	5	

## 'G Matrix' of participant Power Plants

		J		L	M			N	O
		1	2	1	1	2	3		
		Coal	CCGT	CCGT	Coal	3X210	7X210	Coal	Coal
		3x200 & 3x500	432	135	4X210	4x210	4X210	2 x 130	2 x 500
2.10	Satisfaction & Engagement ( Trends for 3 to 5 years )	4	-						
2.11	Satisfaction & Engagement ( Trends for 3 to 5 years )	4	2				5	3	
2.12	Satisfaction & Engagement ( Trends for 3 to 5 years )	4	3			2	4		
2.13	Training & Development /Job enrichment ( Trends for 3 to 5 years )	4	3		2	2	2	3	
2.14	Training & Development / .Job enrichment ( Trends for 3 to 5 years )	3	2		2	2	2	1	
2.15	Training & Development /Job enrichment ( Trends for 3 to 5 years )	4	4		2		1	1	
2.16	Rewards & recognition	4	3	2		1	4	4	
2.17	Rewards & recognition	4	4	3	2	4	2	3	
2.18	Effective /Two way communication	3	3	2	2	3	4	4	
2.19	Effective /Two way communication	3	3		3			3	
2.20	Code of conduct	3	3						
2.21	Code of conduct	3	-		2		4		
2.22	Employee participation		4	2	3	3	2	2	
<b>3.</b>	<b>Society around</b>								
3.1	Hazard management systems	3	3		3	4	3	4	
3.2	Accountability	3	2		2	4	3	4	

## 'G Matrix' of participant Power Plants

		J		L	M			N	O
		1	2	1	1	2	3		
		Coal	CCGT	CCGT	Coal	3X210	7X210	Coal	Coal
		3x200 & 3x500	432	135	4X210	4x210	4X210	2 x 130	2 x 500
3.3	Society	3	4		3	4	3	3	3
3.4	Community initiative		4		1		2	4	3
3.5	Community initiative		3		1		2	4	4
3.6	Sharing/Service through professional bodies representing power industry.	2	4						
3.7	Sharing/Service through professional bodies representing power industry.	4	4		2		3		3
<b>4</b>	<b>Shareholders</b>								
4.1	Share Holders (or else those who have a stake in cos.)	2	-						3
4.2	Share Holders (or else those who have a stake in cos.)		-						
<b>5.</b>	<b>Suppliers</b>								
5.1	Mutual Benefits through supplier partnership		2	2				2	
5.2	Mutual Benefits through supplier partnership		2						
<b>6.</b>	<b>Cost / Productivity / Quality</b>								
6.1	Cost Control	3	4		3	3	3		
6.2	Cost Control	3	4		3	3	3		
6.3	Increased productivity		3		2	2	3		3
6.4	Increased productivity		3	1	2	2	3		3
6.5	Increased productivity		3	1	2	2	4		2
6.6	Quality		4	3	1	2	4		
	<b>Grand Total</b>	<b>97</b>	<b>128</b>	<b>34</b>	<b>66</b>	<b>60</b>	<b>85</b>	<b>87</b>	<b>76</b>



## 'G Matrix' of participant Power Plants

### Rating System

1.	Parameter not monitored	0
2.	Parameter being monitored	1
3.	System in place for monitoring / control	2
4.	Consistency in following systems	3
5.	Continuous improvement in systems & parameters	4
6.	Benchmarking of parameters	5
	For example, customer satisfaction	
	If plant doesn't know customer is satisfied / not	0
	If plant is monitoring the customer satisfaction	1
	If there is a system in place (meeting / feedback on a regular basis)	2
	If the system is followed on a continual basis till date	3
	Marked improvement in customer satisfaction recorded with innovative parameters in subsequent meeting / feedback	4
	Benchmarking with known & successful entity (national/international)	5



## CHAPTER - 4

### BEST PRACTICES IN INDIAN POWER PLANTS

SNo	Topics	Implemented power plant
<b>4.1</b>	<b>Performance improvement - Heat rate &amp; Auxiliary power consumption</b>	
4.1.1	Smart wall blowing system for optimising wall blowing and improving heat rate	Raichur thermal power station
4.1.2	Improvement in hot reheat temperature in Boiler	CESC Limited
4.1.3	Modification in auto furnace draft control logic in ID fan vane scoop combination control	CESC Limited
4.1.4	Utilisation of PADO and the benefits for the thermal power plant	NTPC, Simhadri
4.1.5	Latest techniques for heat rate improvement of power plant	Tata Power, Trombay
4.1.6	Continuous improvement of heat rate of combined cycle power plant	GMR Energy Limited
<b>4.2</b>	<b>Performance Improvement - Reliability &amp; Availability</b>	
4.2.1	Reliability improvement by avoiding inadvertent errors	Reliance Energy Ltd.
<b>4.3</b>	<b>Operation &amp; Maintenance</b>	
4.3.1	Equipment Criticality analysis	Reliance Energy Ltd.
4.3.2	Introduction of super cleaning of Turbine oil	Reliance Energy Ltd.
4.3.3	Innovative boiler maintenance techniques for minimizing boiler tube failure	Raichur thermal power station

***Manual on best practices in Indian Thermal Power Generating Units***

4.3.4	Life extension of coal mill gear box lube oil by Electrostatic liquid cleaning method	CESC Limited
4.3.5	High concentration slurry system for ash handling	CESC Limited
4.3.6	Benchmarking in reduction in startup time of the power plant	Tata Power, Trombay
4.3.7	Innovative methods for reducing capital overhaul time	Tata Power, Trombay
4.3.8	Replacement of aero derivative turbine in very minimal time duration	GMR Energy Limited
4.3.9	LOTO - Lockout and tagout system	GMR Energy Limited
4.3.10	Innovative techniques to minimize the cold startup time of a combined cycle plant	GMR Energy Limited
<b>4.4</b>	<b>Environment Improvement</b>	
4.4.1	Flue gas conditioning by auto controlled dosing of ammonia gas and improving performance of ESP	CESC Limited
4.4.2	Initiatives towards achieving zero effluent discharge	GSEB, Gandhi Nagar
4.4.3	Flue gas desulphurisation system for reducing SOX level	Tata Power, Trombay
<b>4.5</b>	<b>Miscellaneous Projects</b>	
4.5.1	Departmental website - a tool for data and knowledge management and	Reliance Energy Ltd.
4.5.2	Rain water harvesting in a thermal power station	GSEB, Gandhi Nagar
4.5.3	Customer satisfaction index, Customer complaints and redressal mechanism	Tata Power, Trombay

## **4.1. PERFORMANCE IMPROVEMENT – HEAT RATE & AUXILIARY POWER CONSUMPTION**



#### **4.1.1. Case study**

### **INSTALL SMART WALL BLOWING SYSTEM FOR OPTIMISING WALL BLOWING AND IMPROVING HEAT RATE**

#### **Background**

The boiler performance including its ability to meet full load, auxiliary power consumption, net plant heat rate, availability of the unit, operation and maintenance cost etc are significantly affected by the fuel characteristics. Coal firing in the furnace form different kinds of deposits on the boiler tubes.

To improve the performance and thermal efficiency of the boiler, it is important to remove the deposits periodically and maintain the heating surface clean.

Boilers are designed such that the radiation and convective zone heat transfer surfaces absorb the released heat proportionately. Any deviation in heat transfer in radiation and convection zone will affect the function of feed water preheating in the economiser, steam super heating in LTSH, platen super heater and final super heater. This will result in reduction in boiler operating efficiency.

Smart wall blowing system (SWBS) is a selective wall blowing system, operating on auto mode. The operation is controlled based on super heater spray flow and furnace heat absorption at different zones. The system helps to maintain the furnace heat absorption at optimum level thereby maintaining the super heater and reheater sprays within limits.

#### **Present Status**

The conventional wall blowing systems are operated sequentially once in 8 hrs. All soot blowers will be operated 3 times a day.

In conventional blowing system, the furnace condition is not taken into consideration. The changes in fuel characteristics and boiler load are also not taken into account for controlling the soot blowing.

Periodical operation of the soot blowing system leads to significant variation in super heater and reheater spray. Soot blowing requires about 3.3 tons of steam per cycle.

In addition operating blowing system on a clean boiler tube surfaces leads to increase in erosion rate. This leads to increase in boiler tube failures.

### **Project implemented**

Smart wall blowing system was installed for the boiler to optimise the wall blowing.

SWBS consists of an electronic logic system interfaced with existing normal blowing system. The system consists of water wall heat flux sensors installed in between the wall blowers. The sensors have built in thermo couples.

The heat flux sensors are installed in between the wall blowers in four elevations. There are eight heat flux sensors in each wall and totally 32 sensors are mounted on four sides of the water wall.

The arrangement of heat flux sensor is shown in fig.

The two ends of the sensors are exposed to the flame radiation and the stable cooling water side respectively. Sensors continuously give output proportional to the absorbed heat flux.

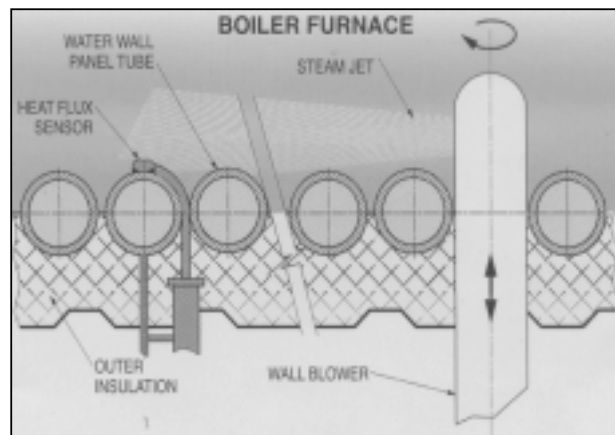

The sensors are connected to the remote SWBS control panel positioned in the control room through transmitters. The SWBS control panel is connected to the conventional soot blowing system. it is an add on facility to the existing soot blowing system.

### **Operation of SWBS**

The heat flux changes continuously depending upon the thickness and heat transfer properties of the deposits. The actual heat flux is measured continuously by the heat flux sensor and monitored with the dynamic set point.



## **BEST PRACTICES IN INDIAN POWER PLANTS**

The super heater spray requirement triggers the operation. The High and low SH sprays are set to desired values. The system either starts or stops the blowing sequence when the spray crosses the highest / lowest set points respectively.

When there is a reduction in the heat flux below the dynamic set value of a particular sensor the adjacent two blowers are actuated automatically. The sequence of heat flux comparison with the set values and the blower by passing/ blowing continues in a sequential manner from wall to wall till the SH spray flow reaches the low set point.

The blowing operation resumes in auto mode when the SH spray flow crosses the high set point with a comparison of heat flux with the set point. The system maintains super heater spray flow within a narrow band.

The trend of super heater spray control with conventional blowing system and SWBS is shown in fig.

Each blower operates once / twice or thrice in a day depending on the heat flux value. Blowers, which are not operated in the first two cycles, are operated compulsorily in the third cycle, irrespective of their heat flux value.

Hence each blower operates atleast once in a day and avoids permanent adherence of the deposits on water wall surface.

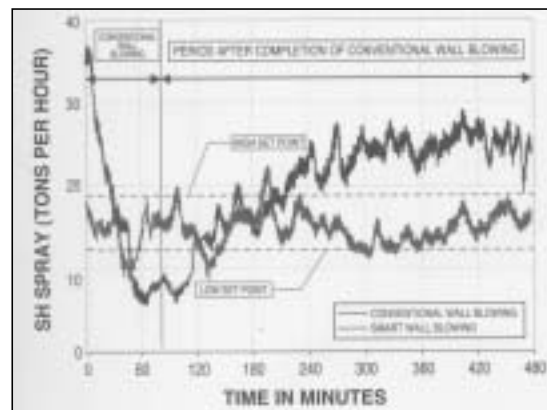

### **Benefits**

Installation of SWBS results in following benefits.

- Reduced variation in SH/RH spray. Hence steady SH / RH steam temperature. This results in improved efficiency of boiler and heat rate of overall cycle.

- Reduced superheated steam consumption due to reduced number of wall blowing.
- The soot blower operation is reduces by about 55 - 60% compared to conventional wall blowing system.
- Reduction in tube erosion due to selective and reduced steam blowing

**Financial analysis**

Annual energy saving of **Rs 52.50 Lakhs** was achieved. The break up of savings achieved is as below.

RH spray reduction	-	Rs 43.50 Lakhs
Reduction in steam consumption	-	Rs 7.50 Lakhs
Material saving due to reduction in erosion	-	Rs 1.50 Lakhs

**4.1.2. Case Study****IMPROVEMENT IN HOT RE-HEAT TEMPERATURE****Background**

BBGS have 2 X 250 MW Natural circulation Double Downshot boilers with low NOx burners. It is provided with Gas Recirculation system for controlling hot Re-heat temperature. The Gas recirculation (GR) duct is provided from ID Fan outlet to rear side of Boiler at 8.5 meter level near bottom ash hopper arch. As per design, GR flow is required for maintaining designed HRH temperature at part load, but no GR flow should be required to attain desired HRH temperature at Full load.

**Previous status**

BBGS experienced problem of low Hot Re-Heat (HRH) temperature (design 535 °C) for a long period since commissioning. Desired HRH temperature normally could not be achieved either at part load or at full load even with considerable amount of GR flow.

This problem had the following adverse effects :

- Low Condenser vacuum (increased steam flow due to low HRH temperature)
- High probability of erosion at end side LP stage turbine blades
- Increase in BFP loading due to high steam flow
- Application of high gas recycling flow to improve HRH temperature, resulted in :
  - ❖ High dry flue gas loss of Boiler due to high flue gas exit temperature
  - ❖ Increased Stack SPM level due to increased gas velocity
  - ❖ Higher ash erosion at boiler back pass
  - ❖ Increased ID Fan loading

### **Project implemented**

The above problems were overcome through a number of steps, the major of which are as follows :

- Re-heater Pendant zone Soot Blowing system has been commissioned and regularly operated as per requirement, depending on Boiler operational parameters
- Boiler has been put on Auto combustion mode leading to optimization of air and coal flow
- Re-heater biasing valves has been put on auto control resulting in matching of left and right side Re-Heat temperature
- When coal condition is worse than design, 5 mill operation is used instead of previous practice of using 4 mills resulting in better combustion
- Re-heater attemperation system has been commissioned and kept in 'Auto' to take care of any excursion in HRH temperature immediately

### **Benefits**

The benefits achieved after implementation of this project are as follows :

- Improvement in HRH temperature; now being maintained at 535 °C (designed) at 262 MW load at turbine inlet

**Manual on best practices in Indian Thermal Power Generating Units**

---

- Reduced steam flow
- Improvement in condenser vacuum
- Saving of auxiliary energy consumption by reduction of ID Fan and Boiler Feed Pump loading
- Reduction in Boiler dry flue gas loss
- Better stack opacity; reduction of SPM by about 25 mg/Nm<sup>3</sup> due to reduced gas recycling

The following table illustrates the above :

Time Period	Unit	LOAD MW	HRH temp Deg C	Steam flow Te/hr	Condenser Vacuum mmHg	Remarks
June-July 2005	1	263	539	815	85	Without GR
June-July 2004	1	262	513	826	94	With GR
June-July 2005	2	262	537	817	84	Without GR
June-July 2004	2	261	515	827	87	With GR

**Financial analysis**

**1. Improvement in Heat Rate :**

The result of increased HRH temperature caused reduction in Heat Rate by considerable amount.

For 20 °C average increase of HRH temperature, Turbine Heat Rate has improved by 10 Kcal/kwh.

**2. Savings in auxiliary consumption :**

- a) Reduction in BFP power consumption due to reduced steam flow  
Energy saved : appx 2.45 mu per annum  
Cost savings : appx Rs 66 lakhs per annum
- b) Reduction in ID Fan power consumption due to reduced flue gas flow  
Energy saved : appx 3.26 mu per annum  
Cost savings : appx Rs 88 lakhs per annum

Unit cost of Rs. 2.70 has been assumed in the above calculation

**4.1.3. Case Study****MODIFICATION IN AUTO FURNACE DRAFT CONTROL LOGIC OF ID FAN VANE-SCOOP COMBINATION CONTROL****Background**

The furnace draft control is kept in 'auto' with a set point of  $-5.0$  to  $-8.0$  mmwc. The 'vane-scoop combination controls' of the running ID Fan/Fans are also placed in 'auto'. Furnace draft controller measures Furnace draft & compares with set point. Output signal is generated & fed to ID Fan 'Vane scoop control'.

Inlet guide vane control is quicker compared to speed control using the variable fluid coupling. However, throttling the inlet guide vane leads to reduction in operating efficiency of the fan.

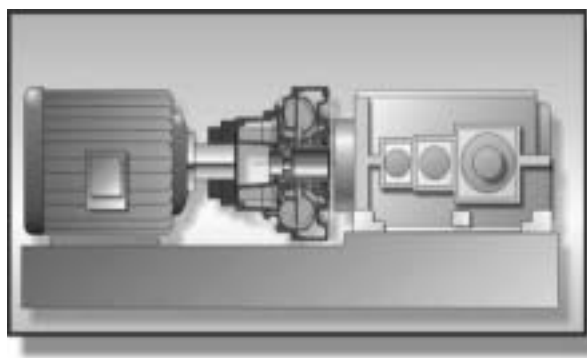

Flow control by controlling the speed (like fluid coupling scoop control) is more energy efficient than inlet vane control though the later is quicker in response. The purpose of the modification of ID Fan operation control logic was to ensure efficient and stable furnace draft control with combined response of vane & scoop.

**Previous status**

As per the original design philosophy, the vanes would modulate first from 35% (lower limit) to 55% (upper limit) as per demand signal. Once it reached limits, the vane remained fixed & demand signal went to operate Scoop. Scoop would take a % of position and desired furnace draft was achieved.

**Area of concern :** The main drawback of the previous control logic was that during high load (full load) the vane opening was limited to 55% whereas the scoop was

nearly at 100% position. It was an energy inefficient control resulting in very high ID Fan power consumption.

### **Project implemented**

Vane control upper and lower limits were made dynamic and compatible with scoop control position feed back. Initially due to the priority set in the process logic, the demand signal modulates the vane. Once it reaches upper /lower limit, scoop starts changing position. When scoop reaches a certain position, the vane upper set point becomes dynamic & increases to higher value (governed by a calculation dependent on scoop position feedback).

Next on receiving further demand signal, scoop remains constant and vane modulates till it reaches changed upper limit. Subsequently the demand signal increases the scoop further. Again the vane upper limit becomes dynamic and after incremental rise it freezes at a higher value.

Operation is governed by the following formula :

$$\text{Upper Dynamic Vane set point} = [(scoop\ feed\ back \times 0.446) + 40]_{min\ 55}$$

$$\text{Lower Dynamic Vane set point} = [(scoop\ feed\ back \times 0.550) + 25]_{min\ 40}$$

*Similar dynamic controlling operation of vane-scoop control is used during lowering operation.*

### **Benefits**

After modification of the control logic, each ID Fan loading came down by 10 amps [at rated generation, each ID takes 115 to 145 amps depending upon coal quality]

**Daily Energy savings: 9,328 kwh**

### **Financial analysis**

**Energy savings : 3.4 mu per annum**

Cost savings : **Rs 92 lakhs per annum** (assuming unit cost = Rs 2.70). This project requires no investment except the modification in the control logic.

#### 4.1.4. Case Study

### **UTILIZATION OF PERFORMANCE ANALYSIS AND DIAGNOSTIC OPTIMISATION SYSTEM AND THE BENEFITS FOR A THERMAL POWER PLANT**

#### **Back ground**

This system was supplied by M/s. BHEL as part of main plant turnkey package. The system is an online package aims at evaluation of performance, diagnosis and optimization of various equipment / processes in the power plant by developing online thermo physical models and with appropriate data validation cum reconciliation to eliminate errors, if any. The package is user friendly and has an interfacing facility with DDCMIS system. It acquires data of around 900 parameters over a period of 5 minutes and displays the results based on average parameters.

#### **Components and Functions:**

The components and functions are SR - X, SR - 1, SR - V and SR - 4.

SR - X is a software system for processing the raw data transmitted from DDCMIS. Data processing includes arithmetical operations, manual entries, linking up with formulae / steam tables, data presentations and data storage. The systems covered are boiler and auxiliaries, TG and auxiliaries.

SR -1 is the life time monitor. It records the life time consumption by continuously monitoring operating temperatures and pressures for critical components of boiler such as Drum, MS and HRH headers. The system calculates the residual life by considering both creep and fatigue.

SR - V does data validation and reconciliation. Data validation is done through neural networks. Data reconciliation is based on VDI 2048 guidelines.

SR - 4 does on line optimization. It includes Soot blowing optimisation, boiler combustion optimisation. It evaluates performance of air-heaters, condenser, HP heaters,etc

**Benefits**

- TG cycle heat rate is being optimized by minimizing the deviations due to all operating parameters. The losses are being shown in monetary terms.
- Prediction of performance with a change in any variable is made possible. This helps operator to take dynamic decisions
- Visualisation of thermal models for various equipment and the performance levels.
- Root cause identification made easier with performance analysis for equipment like HP Heaters / LP heaters / Condenser / Air pre-heaters.
- Optimized soot blowing – by following the advises after evaluating the heating surfaces effectiveness and cost benefits
- Trending of a measured / calculated parameter helped in early detection of faults.
- History of equipment performance can be maintained.
- Helps in refreshing skills of existing operation engineers and development of fresh engineers.

**4.1.5. Case study****HEAT RATE IMPROVEMENT IN 500 MW THERMAL POWER PLANT****Background**

Presently, Trombay Thermal Power Station of Tata Power Company has an installed capacity of 1330 MW comprising 1x150 MW plus 2x500 MW thermal units and 1x180 MW Combined cycle unit. This case study deals with practices evolved for Heat Rate Improvement in 500 MW units.

Both 500 MW unit boilers (namely Unit 5 & Unit 6) have multi fuel firing capability. Unit 5 boiler can fire oil (Low Sulphur Heavy Residue-i.e.LSHS from refineries), gas or coal while Unit 6 Boiler can fire oil (LSHS) or gas in any proportion simultaneously. At present Unit 5 runs on Indonesian coal while Unit 6 runs on oil (LSHS).



---

**BEST PRACTICES IN INDIAN POWER PLANTS**

---

The operating parameters of these units are as follows:

<b>Parameter</b>	<b>Unit 5</b>	<b>Unit 6</b>
Main Steam Pressure	166 Bar	166 Bar
Main Steam Temperature	540 <sup>0</sup> C	540 <sup>0</sup> C
Reheat Steam Pressure	40 Bar	40 Bar
Reheat Steam Temperature	540 <sup>0</sup> C	568 <sup>0</sup> C
Design Heat Rate	2415 Kcal/Kwh	2280 Kcal/Kwh
Commissioned in Year	1984	1990

Unit heat rate is a measure of operation efficiency which ultimately has an impact on fuel consumption, cost of power & environment. The cost of fuel is continuously on the rise. To conserve the fuel and minimize the cost of power, it is our endeavor to continuously improve the heat rate of the plant.

### **Previous Status**

Some deviations were observed between actual & ideal heat rate on these units. Although unit heat rate is maintained within operating range, special attention was given by management to improve the heat rate of the units further by forming a team comprising engineers from operation and maintenance departments. The team took aspirational targets for heat rate reduction. Various ideas were generated in brainstorming sessions. Following areas emerged as improvement areas:

- i. Units at Trombay are subject to load variations during the day/night depending on the electrical grid requirements which affects the heat rate. Load variation could be in the range of 160 MW to 500 MW. Hence it was decided to have “On line Heat rate Monitoring “ which could give hourly average Heat Rate to facilitate better monitoring, analysis & control by operation group.
- ii. Unit 5
  - a) Higher Boiler flue gas exit temperatures (175<sup>0</sup> C as against a design of 145<sup>0</sup> C causing increased chimney losses.
  - b) Slagging in Unit 5 Boiler

c) Drop in High Pressure Turbine module efficiency from 89% to 83%

iii. Unit 6

Lower economizer water inlet temperature by 6 degC

Higher Makeup water consumption

### **C. Project Implementation and challenges faced**

#### **1. Heat Rate - monitoring & analysis**

##### **i) On Line Monitoring:**

This was addressed on the basis of first principle i.e. “What gets measured gets controlled”. Heat rate is computed from Mkal of heat input derived from on line measurement of fuel flows & Generator Electrical output. Average calorific value of coal/oil is taken as input for computation. On line monitoring facility was developed in-house on Data Acquisition System .It provides a display of set of operational parameters which affect heat rate & gives on line deviation from optimum value. Such deviations are analyzed in each shift & corrective action ,if any, is taken .Such actions include maintaining steam temperatures with minimum sprays, need based soot blowing ,adjusting coal mill outlet temperatures etc. It is reviewed on daily basis by senior management & any additional operation/maintenance actions which can help improving heat rate, are taken.

##### **ii) Monthly review:**

Station Heat Rate is one of the parameters in “Balanced Score Card “ of divisional head & Monthly review of unit heat rates is carried out by Divisional head & actions discussed so as to remain within the norms set by Maharashtra Electricity Regulatory Commission .

##### **iii) Fuel Measurement:**

Heat rate computation is as accurate as accuracy of fuel flow measurement & main challenge lies in ensuring that fuel flow measurement is accurate.

Therefore Mass flow meters with an accuracy of 0.25 % are installed for metering oil consumption and weightometer with 0.5 % accuracy are installed for coal fed to bunker. Periodic checks/calibrations are done to ensure sustenance of accuracy of these measurements. Bunker level is monitored by electromechanical level transmitter. Also, rigorous quality checks are done on imported coal at load port, disport & Trombay. Coal quantities are also verified through quarterly coal surveys of coal piles. Further refinement in coal measurements is being done.

## **2. Unit 5**

### **i) Reducing Boiler Flue Gas Exit Temperature**

Unit 5 boiler is originally designed to fire Indian coal (8% moisture, 25 % ash content and 31% volatile matter). However due to stringent environment norms set in terms of SO<sub>2</sub> emission & ash generation for Trombay Thermal Station , it is not possible to use Indian coal on this unit now. Therefore in 2001, trial of Indonesian coal (24 to 30% moisture, 1 to 2 % ash and high volatile matter 44%) was successfully done. However operational limitation of this coal is due to high volatility which makes it prone to fire in mills. Hence Coal mill outlet temperature was restricted to 55°C (as against 77°C for Indian coal) to avoid mill fires. This required use of relatively more cold primary air limiting heat pick up in air-pre heater causing higher exit flue gas temperature at Airpreheater(APH) outlet and the consequent increase in unit heat rate.

The obvious solution to the problem was to increase the mill outlet temperature for maximum possible recovery of heat from flue gases. However it was the first time that Indonesian coal was being tried on a 500 MW unit in our country & stakes being high, there was an apprehension about coal mill fires / explosion. In fact we also faced minor cases of duct ruptures. Some mill modifications were also carried out. After extensive trials & analysis of - on line data by in-house team of operation & maintenance engineers, confidence was built up & the coal mill outlet

temperature was gradually raised to 65<sup>0</sup> C. This has helped in bringing down the flue gas exit temperature to about 165<sup>0</sup> C, a reduction of 10<sup>0</sup> C by change of operation practice.

Improvement in heat rate is a continuous process & some changes in design are being planned in next capital overhaul of unit 5 as follows.

- Partial shielding of PA section of APH to reduce the hot primary air heat pick up.
- Reverse rotation of RAPH i.e, bring secondary air first in contact with heated element of RAPH instead of primary air
- Replacement of RAPH basket elements.

The above measures are expected to reduce heat pick up in primary air and increase heat pick up in secondary air side of APH. This is expected to decrease the primary cold air (which bypasses air pre heater) requirement for mills which will further help in reduction in flue gas temperature at APH outlet

ii) **Reducing Slag formation in Boiler**

Original design of this unit is for Indian coal having ash fusion temperature of 1400 deg C. However Indonesian coal is having ash fusion temperature in the range of 1170 to 1230 deg C. Slagging index for such coal being higher , it is prone for slagging causing lower heat absorption mainly in Super heater Divisional panels. Trials of injecting a special chemical on fire side were carried out to minimize impact of slagging. Dosing quantity & frequency was optimized. Photograph shows change /improvement in terms of clean heat transfer surfaces. Gain in terms of increased heat absorption & decrease in flue gas exit temperature was however limited to maximum 4 deg C.

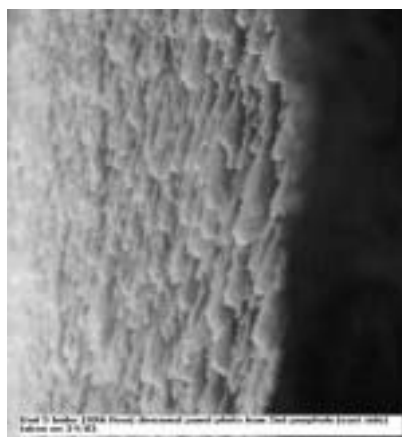
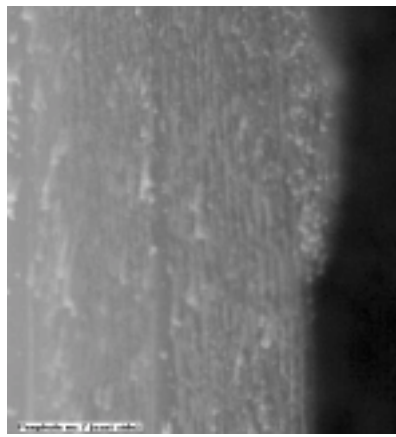
**Before Chemical Injection****After Chemical Injection****iii) Optimization of Soot Blowing:**

Earlier soot blowing was being done in a conventional manner periodically to clean the boiler heat transfer surfaces. Incorporating an intelligent soot blowing system designed to operate soot blowers as per needs would involve outage of the unit for installation of heat flux sensors and other major expenditure. Alternatively, software was developed in-house using the existing data to display in Control Room the effect of operating various soot blowers. After observations of impact of operation of soot blowers in various segments & collection of data, an operating procedure is evolved & operation of soot blowers is optimized. Thus need based soot blowing has helped in economizing steam for such operation.

**iv) HP Turbine Module Replacement**

Internal efficiency of HP & IP turbines is being monitored periodically. Original efficiency HP turbine module at the time of commissioning of unit 5 in 1984 was 89%. Over the years, this efficiency had reduced to 83%. Hence a decision was taken to replace this module during 2004 overhaul. After replacement, there was a gain of about 25 Kcal/Kwh in heat rate.

**3. Unit 6****a) Normalizing Economizer Feed Water inlet temperature :**

It was observed that feed water temperature at economizer inlet was maintaining lower than design by 5 – 6° C. The performance of feed water heaters was checked. After studying the results, a decision was taken to inspect the heaters during the outage. The inspection revealed holes due to erosion in the diaphragms that separated the feed water inlet and outlet water boxes, causing partial bypassing of water in the heater in HP heater, leading to lower feed water temperature. Corrective action was taken and the heater performance was restored back to normal. Thus the online availability of the relevant data as well as the facility of historising the data has made the analysis of the problems easier.

**b) Minimising Auxiliary Steam Consumption & Makeup Water:**

Considerable steam is required in oil fired unit for oil heating & atomizing. Pour point of LSHS oil used at Trombay station is around 50 deg C. Below this temperature, oil would solidify. Therefore Auxiliary steam is passed through coils in the tank to heat & keep LSHS oil in fluid condition for pumping

Such steam consumption for fuel tanks heating tends to increase heat rate & make up .This is optimized by limiting heating steam quantities by changing operational procedures & operating range of fuel oil tank temperatures. Other measures such as diverting soot blowing header drain to a closed system, eliminating leakages in water/steam system were also taken to minimize make up water heat losses.

**Benefits**

- i) Soot blowing system optimization : Fig 1 shows reduction in number of soot blowing operations after optimization in unit 5. Long retractable operation could be reduced by 60 % & wall blowers by 75 %.It resulted

## BEST PRACTICES IN INDIAN POWER PLANTS

in reduction of soot blower steam consumption by 15 MT/day with an equivalent fuel saving of Rs 31 lakh per annum.

Fig- 1

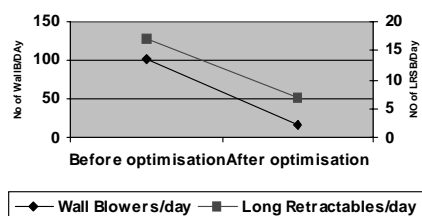

- ii) **Fuel oil tank farm heating steam optimization:** By adjustment of oil tank temperature through change in operating procedure, steam saving of 100 MT per day is achieved resulting in fuel saving of about 2 crores per annum.
- iii) **Improvement in heat rate :** Improvement in heat rate on account of above operational measures is shown in Table 1.

Improvement	Heat Rate Kcal/Kwh
Replacement of HP turbine module	25
Reduction in flue gas exit temperature	10.0
Normalising feed water inlet temperature	6
Soot blower optimization	1.5
Fuel oil tank heating steam optimization	6.0

Thus on line monitoring of heat rate has helped in analysis of reasons for deviation & in taking corrective actions for continuous improvement in heat rate of the units.

Thus even small margins available for improvement can be tackled with on line monitoring & analysis of heat rate .Such gain is ultimately passed on to consumer through fuel saving.

#### **4.1.6 Case Study**

### **CONTINUOUS IMPROVEMENT IN HEAT RATE OF COMBINED CYCLE POWER PLANT**

#### **BACKGROUND**

Optimization process was initiated by the plant team, which targeted every component of the plant. Detailed and systematic study was conducted for all the target areas, which covered all equipments of the plant. External agency was involved in conducting plant Energy Audit and studying the efficiency of process and identifying the areas of improvement.

The optimization study can be divided into following areas:

1. Plant startup time reduction and heat rate optimization to reach full load in minimum time with minimum fuel consumption.
2. Plant shutdown time reduction and heat rate optimization to shutdown plant safely, timely and with minimum fuel consumption.
3. Plant heat rate optimization during normal operation by improving the individual equipment performance and better process monitoring & control.
4. Minimizing the plant auxiliary power consumption when plant is not in operation by measures like switching off transformers, lighting & HVAC load optimization and developing equipment preservation and normalization procedure.
5. Incorporating recommendation given by external agency after the detailed energy audit.
6. Incorporating various energy conservation schemes like recycling of waste naphtha.
7. Studying the plant trips and rectification of the same to reduce the energy loss occurring by trips.
8. Optimizing auxiliary consumption of the plant during operation and during shutdown



9. Incorporating plant islanding scheme for islanding plant to house load during grid disturbances and minimizing loss and time for restoration to normal operating condition.

**Previous Status**

The plant startup time was 9 hrs for cold condition, 5hrs for warm start and 3hrs 50min for hot start. The plant startup heat rate was 2300 Kcal/kwh for coming to 220MW from 0 MW. Will all the modification project implementation the plant startup time is 6hrs for cold condition, 4hrs for warm condition and 2hrs 9min for hot condition.

The startup heat rate is now 2150 Kcal/Kwh. The efforts are still on to achieve 1hrs 30min startup time for hot condition by this year. Similarly plant shutdown time was optimized from 1hr 30min to 45min. Plant shutdown heat rate was optimized and reduced from 2500 Kcal/Kwh to 2350 Kcal/Kwh. With all the improvements the plant steady state heat rate has improved by 40 Kcal/Kwh.

**Projects Implemented for heat rate improvement**

Following projects were implemented

1. DeNox water management
2. Improvement of atmospheric condensate collections from all gas turbines inlet air chilling system. Coalescer was added in the air intake path for better condensate recovery. This has resulted in reduced water requirement for outside as in-house water generation has improved.
3. Gas Turbine output improvement by T#48 problem rectification.
4. Load rejection scheme implementation to avoid trips during grid disturbances.
5. Improvements and modifications done to overcome plant recurring trips
6. Improvements in process monitoring and control done. Auto starts / stops logics for various drives implemented
7. Chillers performance improvement
8. Fire hydrant system improvement

***Manual on best practices in Indian Thermal Power Generating Units***

---

9. Providing solenoid valves for seal flushing requirement.
10. Waste fuel recycling
11. Substituting glass wool insulation for chilled water lines by PUF insulation.
12. Plant online performance monitoring system developed and implemented for better monitoring and control
13. Optimizing power consumption for plant extended shutdown preservation activities
14. Fuel nozzles choking problems which were resulting in Gas Turbine lower performance is being overcome by providing purging system for Fuel nozzles

The details of the projects are enclosed as annexures.

**Challenges faced**

Major challenges faced during the project implementation were time constraints as we operate as a peaking plant and our plant operation depends on the load requirement by KPTCL. Before implementation of most of above projects experiments or simulations were carried out to see that modifications done will have positive and desired effect in the system.

Some of the above problems were reoccurring type which was resulting in big loss to us in terms of money and time, both were overcome with above efforts put up by the team.

Other main challenge is daily start and stops of the plant which creates more thermal stress to majority of our plant equipments and also results in more maintenance of the equipment. Above projects were done along with all other scheduled activity.

Daily start ups and shut downs of the plant is also resulting in more fuel burning and end resulting into high specific fuel consumptions and high heat rate. With above modifications and projects implementation we have tried to overcome such effect to some extent.

**Benefits**

- The plant could run with out availability of town water supply during period of water scarcity.
- The overall heat rate has improved
- Availability and reliability of the plant has improved.
- Plant overall output has improved.
- Resulted in saving of auxiliary consumption during zero load dispatch time.
- Customer satisfaction index has further improved. Mainly KPTCL with above project implementations considers as more reliable and we take less time to come to full load dispatch conditions.

**Financial analysis**

Saving in plant steady state heat rate is 40 Kcal/Kwh @ 220MW

Considering naphtha gross calorific value as 11340 Kcal/Kg and present cost of naphtha to plant of Rs 33.4 / kg, saving is approximately Rs 26000 per hour.



## **4.2. PERFORMANCE IMPROVEMENT – RELIABILITY & AVAILABILITY**



#### **4.2.1. Case study**

### **RELIABILITY IMPROVEMENT – AN INNOVATIVE APPROACH FOR THERMAL POWER STATION**

#### **Background**

Reliability means “The ability of a system or component to perform its required functions under stated conditions for a specified period of time.”

A power station is subjected to various internal and external demanding parameters, which try to affect its reliability. A power-generating unit can trip due to various reasons. The main need for tripping is the safety of the human beings and the equipment. Also, the equipments / sensors that sense these parameters may malfunction, and it also can lead to tripping of the unit. Each forced outage causes generation loss and hence revenue loss for the company.

One tripping of a unit causes a loss of availability to the tune of 0.01% for DTSP, assuming that the unit synchronises within 2 hours.

Generally each tripping is followed by forced outage of unit because of secondary effects of the tripping. Such trippings could be because of problems of

- Instrumentation
- Electrical system
- Mechanical system
- Regional electricity grid
- Inadvertent human errors

One aspect of these avoidable trippings is failure of system components. Also other aspect of these avoidable tripping is failure of people who operate and maintain the plant.

So the focus of Operation & Maintenance is towards reducing such avoidable trippings.

## ***Manual on best practices in Indian Thermal Power Generating Units***

---

The practices adopted at Dahanu Thermal Power Station for reducing the avoidable trippings are described in the following case study.

### **Present Status**

The power generating units were commissioned in 1995-96. During the initial stage of stabilization of the units, it has faced a lot of teething problems / symptoms. There were very high number of trippings and the trend is shown below.

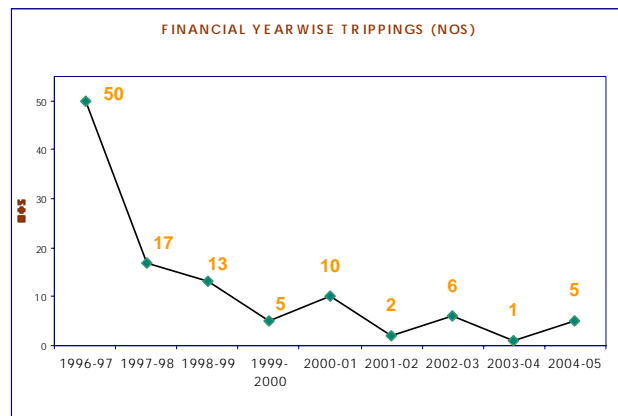

### **Project implemented**

During the stabilization, the focus was to establish the reason for tripping of units and further rectify the problem causing each tripping. Thereafter potential tripping cases were taken up for identification and rectification. Subsequently quality tools are being deployed for further improvement in the system. Various systems being practiced are described below.

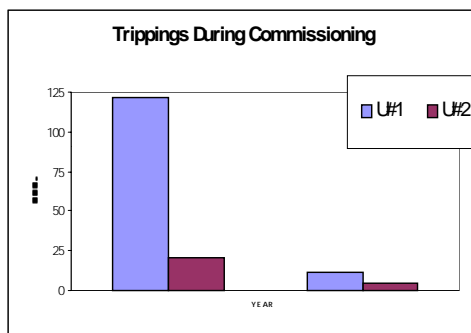

### **Tripping Analysis**

To analyze each and every tripping and identify the causes, a “Tripping Analysis Team” was established. The basic function of the “Tripping Analysis team” was to analyse and arrive at the exact cause of the tripping, and also to recommend any modification in the system.



The modifications suggested by the “tripping analysis team” were accepted by the Original Equipment Manufacturer and implemented in unit # 2. The success of this system can be seen by the difference in number of trippings of two units in initial days.

### **Event Analysis**

To further strengthen the tripping analysis team, a system of “Event analysis” was established. Here the difference was that any event, which had a potential of leading towards tripping or even generation loss, were identified and analysed.

This helped in avoiding generation loss as well as in many cases tripping of unit. This analysis also gave suggestions for system and procedures modifications. A fortnightly report of analysis of events is generated regularly for past 7 years.

These reports are reviewed at various levels up to divisional head and circulated for dissemination.

### **System Approach**

Quality management and environment management systems are established. Under these systems all the trippings and potential events that could result in trippings are considered as non-conformity. To dispose off these non-conformity, corrective and preventive actions are required as suggested by the tripping / event analysis team.

The system of trip analysis is a closed loop system. That means once after establishing the actual cause for the event, it is rectified by way of corrective and preventive action. These modifications or improvements are converted into quality improvement plans (QIPs) for further documentation and record.

### **FMEA – Failure Mode Effect Analysis**

Failure Mode Effect Analysis is nothing but dissection of a system from the point of view of its chances of failure, modes of failure and prevention of the same. This analysis is carried out to identify potential failure.

The results coming out of the analysis are given a weightage based on severity, frequency and detection of failure. A risk priority number (RPN) is arrived at by this

## ***Manual on best practices in Indian Thermal Power Generating Units***

---

analysis and higher the RPN, more the probability of failure. This was carried out for major systems like coal mills, CW pump house, C & I logics for operation of important auxiliaries, etc.

This has given an insight in the major important components of the system, their importance vis-à-vis other equipments and the chances of its failure. With help of this analysis potential causes of failure and their preventive remedial measures are identified.

### **Avoidance of inadvertent human errors**

FMEA exercise has considered the human errors also, to avoid the sense of complacency and improve the response of the desk engineers. More than 100 internal workshops were conducted for various topics like,

- Past human errors.
- Past trippings.
- Potential failures.
- Defect analysis.
- Areas of improvements.
- Reduction in start-up / shut down time.

### **Benefits**

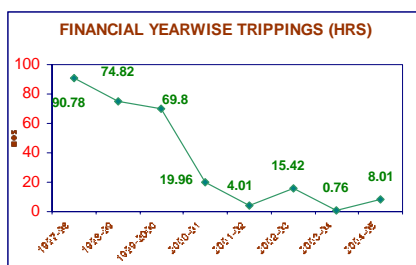

Over the year DTPS non- availability due to trippings has reduced. This is displayed by the Number of hours lost due to unit trippings. The reduction in trippings is depicted in the graph.

All the trippings in the later years were of due to some newer reasons. FMEA has helped us in overcoming such problems.

The knowledge dissemination and various analytical tools have helped in minimising the trippings due to human errors. There has not been a single tripping due human error in last 5 years.

## **4.3. OPERATION & MAINTENANCE**



### 4.3.1. Case study

#### **EQUIPMENT CRITICALITY ANALYSIS – A TOOL FOR IMPROVING RELIABILITY AND AVAILABILITY**

##### **Background**

The Equipment Criticality analysis has been carried out to scientifically determine the equipments, which are having eminent influence on the performance of Thermal Power Station. These critical equipments will be monitored more attentively, to further improve the maintenance as well as operation performance.

A list of Critical Equipment was available for close monitoring of these equipment, to ensure the plant availability at the highest level. However there is a need to testify all the equipments on some logical & scientifically proven basis & add or modify the present list of critical equipments, if required.

It was identified that the “Equipment Criticality Analysis” is an excellent tool for this purpose. It has considered all the aspects of equipment criticality to arrive at the “Criticality Index” for the equipments. This criticality Index has helped to list all the equipments right from the most critical to the least one.

The most critical equipments will be dealt with more attention, including its operation, maintenance, condition monitoring, spares availability etc; to improve the overall plant performance. The criticality index thus decided will be documented in the Maintenance module of the ERP system by incorporating this in equipment parameters. All Criticality Score, Priority Score & Criticality Index will be put in the system as equipment parameters.

##### **Methodology**

Equipment Criticality Analysis is the method of assessing criticality, based on a point rating system, which considers the effect of equipment breakdown on the plant performance.

### ***Manual on best practices in Indian Thermal Power Generating Units***

---

The Criticality Index is calculated by multiplying Criticality score & Priority score. The Criticality score is calculated based on effect on generation, Environment and Safety, Service Level, Efficiency & Aux Power and Redundancy Factor. The Priority score is calculated based on Frequency of Failure, Spare Part Cost, Average Down Time and Man Power Cost.

The Criticality Index for all major equipments has been evaluated as per the criteria given below.

#### **Criteria for Criticality Index**

Criticality index is based on following elements:

##### 1. Effect on Generation - (G)

<b>Effect on the element</b>	<b>Score</b>
No significant consequences on generation due to failure	1
Generation loss < 20%	2
Generation loss < 50%	3
Unit tripping	4
Station tripping	5

##### 2. Effect on Environment and Safety - (E)

<b>Effect on the element</b>	<b>Score</b>
No effect on Environment and Safety	1
Very minor effect	2
Failure leads to an accident or significant impact on environment	3

##### 3. Effect on Service Level - (S)

<b>Effect on the element</b>	<b>Score</b>
Failure will not affect the work of succeeding equipment	0
Failure will affect the work of succeeding equipment	1

---

**BEST PRACTICES IN INDIAN POWER PLANTS**

---

## 4. Effect on Efficiency &amp; Aux Power (A)

Effect on the element	Score
No effect on Efficiency & Aux Power	0
Very minor effect	0.5
Failure leads to a major effect on Efficiency & Aux	1

## 5. Redundancy Factor (RF)

Effect on the element	Score
If there is no standby unit for the failed equipment	1
If the number of standby unit is 1	0.5
If the number of standby unit is 2	0.33

$$\text{Criticality Score} = (G+E+S+A) \times RF$$

Where:

- G = Effect on Generation  
 E = Effect on Environment and Safety  
 S = Effect on Service Level  
 A = Effect on Efficiency & Aux Power  
 RF = Redundancy Factor

## 1. Frequency of Failure (FF)

Effect on the element	Score
Once per year or rare	1
Twice in a year or once per six months	2
Four times in a year or once in $\frac{3}{4}$ months	3
Frequent failures or more than 4 failures in a year	4

## 2. Average Down Time (ADT)

Effect on the element	Score
If Down Times is 0 to ½ Day	1
If Down Times is 1/2 to 1 Days	2
If Down Times is 1 to 3 Days	3
If Down Times is 3 to 7 Days	4
If Down Times is more than 7 Days	5

## 3. Spare Parts Cost (SPC)

Effect on the element	Score
Cost of spares up to Rs 25,000/-	1
Cost of spares from Rs 25,000/- to 50,000/-	2
Cost of spares from Rs 50,000/- to 1,00,000/-	3
Cost of spares from Rs 1,00,000/- to 5,00,000/-	4
Cost of spares from Rs 5,00,000/- to 10,00,000/-	5
Cost of spares from Rs 10,00,000/- to 50,00,000/-	6
Cost of spares from Rs 1,00,00,000/- to 5,00,00,000/-	7
Cost of spares above Rs 5,00,00,000/-	8

## 4. Man Power Cost (MPC)

Effect on the element	Score
If Cost of Man Power to attend the failure is Rs 10,000/- or less	1
If Cost is form Rs 10,000/- to 1,00,000/-	2
If Cost is above Rs 1,00,000/-	3

$$\text{Priority Score} = (\text{FF} \times \text{SPC}) + (\text{ADT} \times \text{MPC})$$

where

FF = Frequency of Failure

SPC = Spare Part Cost

ADT = Average Down Time

MPC = Man Power Cost



---

**BEST PRACTICES IN INDIAN POWER PLANTS**

---

**Criticality Index = Criticality score x Priority score**

**Findings**

The Equipment Criticality Analysis was carried out. Below is the list of top 20 equipments in descending order of their criticality indices.

S No	Equipment Description	Criticality Score (0.66 - 10)	Priority Score (2-47)	Criticality Index = Criticality Score x Priority score (1.32 - 470)
1	Main Generator Elect. (294mva) - U # 1	8.0	23.0	184.0
2	Exciter U # 1 & 2	8.0	22.0	176.0
3	220 kV Circuit Breaker(Gt)	9.0	18.0	162.0
4	Generator X'mer (315 MVA) U # 1 & 2	8.0	20.0	160.0
5	Hp Turbine U # 1 & 2	6.5	19.0	123.5
6	Ip Turbine U # 1 & 2	6.5	19.0	123.5
7	Lp Turbine U # 1 & 2	6.5	19.0	123.5
8	Pms System Unit # 1 & 2	7.0	17.0	119.0
9	220 Kv Circuit Breaker(FDR)	8.0	14.0	112.0
10	Mop (Main Oil Pump) U# 1&2	6.5	16.0	104.0
11	220 KV Main Bus	9.0	9.0	81.0
12	220 KV Ct	8.0	10.0	80.0
13	220 Kv Ipt/Cvt	8.0	10.0	80.0
14	NGT Cubical	7.0	11.0	77.0
15	Station X'mer (60MV) U # 1&2	9.0	8.0	72.0
16	220 Kv Isolator	8.0	9.0	72.0
17	Fd Fan - 1&2ab	5.5	12.0	66.0
18	Id Fan - 1&2ab	5.5	12.0	66.0
19	Pa Fan - 1 & 2ab	5.5	12.0	66.0
20	Boiler Unit # 1 & 2	6.5	10.0	65.0

**Analysis**

After the “Criticality Index” calculation as discussed above, all the equipments were classified into three categories (A, B & C) depending on their contribution to the total Criticality Index score.

<b>Equipment</b>	<b>Total Criticality Index score</b>	<b>% Contribution to Total Criticality Index score</b>	<b>No. of Equipments</b>	<b>Individual Criticality Index rating</b>
Class-A	3019.50	49.12 %	35	> = 60
Class-B	2074.00	33.74 %	64	22.5 to < 60
Class-C	1053.44	17.13 %	110	< 22.5
Total	6146.94	100 %	209	

**Recommendation / Action Plan**

The class A & B equipments will be closely monitored during their operation, maintenance & condition monitoring. MTBD (Mean Time Between Defects) & MTTR (Mean Time To Repair) study will be carried out for these equipments on regular (Half yearly / Yearly) basis. The frequency of maintenance may also be reviewed after the MTBD & MTTR study.

Further, the exercises of parent-child relationship, spare structure details, trouble-shooting guide & critical parameters will be started with these equipment.

**WORK SHEET FOR EQUIPMENT CRITICALITY ANALYSIS**

Sr. No	WG CODE	EQP CODE	Equipment Description	Effect on Generation (G) (1 - 5)	Effect on Environment & Safety (E) (1 - 3)	Effect on Service Level (S) (0 - 1)	Effect on Efficiency & Aux Power (A) (0 - 0.5 - 1)	Redundancy Factor (RF) (1 - 0.5 - 0.33)	Criticality Score (G+E+S+A) X RF (0.66 - 10)	Frequency of Failure (FF) (1 - 4)	Average Down Time (ADT) (1 - 5)	Spare Parts Cost (SPC) (1 - 8)	Man Power Cost (MPC) (1 - 3)	Priority Score (FF x SPC) + (ADT x MPC) (2-47)	Criticality Index = Criticality score x Priority score (1.32-470)	Class

Confederation of Indian Industry  
CII – Sohrabji Godrej Green Business Centre

BEST PRACTICES IN INDIAN POWER PLANTS

**4.3.2. Case study****INTRODUCTION OF SUPER CLEANING OF TURBINE OIL****Background**

Lubrication oils are being used in various equipments, out of which turbine lubrication system is very important and critical application. Servo prime-46 of M/s. IOC make is used for turbine bearing lubrication and Governing system. The major parameters of the lube oil like viscosity, moisture, and mechanical impurities, TAN etc. are being maintained within limits, by inbuilt centrifuging and top-up.

However the oil in use picks up contamination from wearing parts and the wear debris further pass through the system and in turn generate more contaminants, which can be described as a self-escalating snow balling process.

Smaller contaminant particles are larger in number than larger contaminant particles. Only these smaller particles can enter clearances and cause damage to mating parts.

The super-cleaning initiated to reduce wear tear of equipment components and increase the life of lubricating oil by keeping check on contamination by dedicating two units of Electrostatic Liquid Cleaner –ELC 100LP.

**Present Status**

The Filtration particle size of Duplex filter element & Main oil tank filter element is 37 µm and 250 µm respectively. This indicates that particles size up to 37 µm can only be filtered on line.

Turbine oil is supposed to maintain ISO 11/9 to 13/10 level of cleanliness, which is equivalent to 'NAS 7' and below. However it was observed that NAS level of oil in use is 12+ with present on line cleaning system.

- ❖ The frequent chocking of Duplex Filter was noticed with the existing on line filtration & centrifuging system.
- ❖ The thick sludge of observed at the bottom of Main Oil Tank during overhauls.
- ❖ Governing problem faced resulting in two tripping of the unit.
- ❖ Scratching and scouring marks were observed on the turbine and generator bearings and journals during overhauls.

**Project implemented**

Two nos of Electrostatic Liquid cleaner-ELC-100LP has been dedicated to each Main oil Tank (MOT) to super clean the Turbine oil. The oil supply is taken from MOT and outlet is connected back to MOT.

**Principle of operation of electrostatic liquid cleaner**

ELC is an Electro static liquid cleaner and works similar to the principle of ESP (Electro Static Precipitator). Contaminants in oil such as magnetic / nonmagnetic, organic/ inorganic, resinous matter or sludge etc are either positively or negatively charged due to the contact potential difference with oil.

When oil is passed through an electric field, positively charged particles are drawn to the negative pole and vice versa. Neutral contaminants are drawn and deposited by gradient force to the edge of the die electric media where the intensity of the deformed electric field is highest.

When corrugated die electric media (collectors) are inserted between electrodes, the electric field is deformed and die electric polarisation occurs at the tips of the corrugation. The electric field is the strongest at the tips and particles are drawn and deposited on opposite electric poles and removed from oil.

**Benefits**

Two nos of ELC-100LP Machines are dedicated for the cleaning of Turbine oil. The oil cleanliness level of NAS 7 has been maintained. This has resulted in following benefits.

- Duplex Filter chocking has been reduced considerably. Loss of oil from the system has reduced due to reduced cleaning of Duplex Filter, there by less draining of oil from the filter.

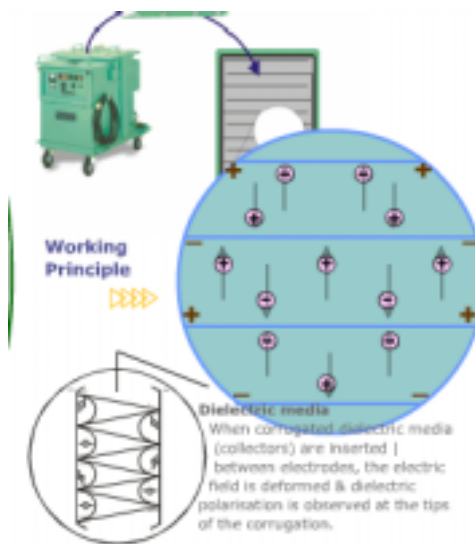

### ***Manual on best practices in Indian Thermal Power Generating Units***

---

- Average Oil consumption has been reduced to 76 barrels from 145 per year.
- Reduction in sludge formation at the bottom of Main Oil Tank.
- No Governing problems are faced due to chocking of governing components.

#### **COST SAVING DUE TO SAVING IN SPARES (TURBINE BEARINGS & DUPLEX FILTER STRAINER) AND OIL.**

- Conservation of oil and better environment due to lesser need for disposal of used oil.

The reduction in oil consumption pattern is shown in the graph:

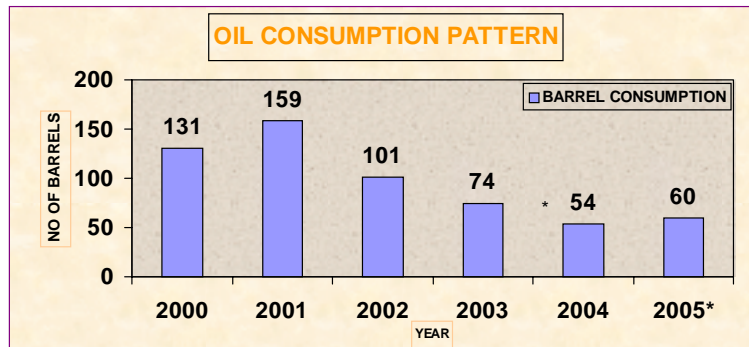

#### **Financial analysis**

Installation of super cleaning system has resulted in many tangible and intangible benefits.

Total cost saving of **Rs. 71.96 Lakhs** has been achieved .The break up of saving is as below.

Cost saving due to Turbine spares	-	Rs 38.00 Lakhs.
Cost saving due to reduction in oil top up	-	Rs 14.21 Lakhs.
Cost saving due to tripping of unit due to chocking of governing components.	-	Rs 19.75 Lakhs.

**4.3.3. Case study****INNOVATIVE BOILER MAINTENANCE FOR MINIMISING BOILER TUBE FAILURE****Background**

In Indian Power plants, Boiler tube leakage is one of the major reasons for forced outage. The forced outage leads to reduction in power generation and hence reduction in plant load factor and increased oil consumption due to increased cold start up of boilers.



Over stressing, Starvation, Overheating of tubes, Creep life exhaustion, Stress corrosion, Waterside Corrosion, Fireside Erosion, Hydrogen embrittlement, Age embrittlement, Thermal shocks, Improper operating practices, Poor maintenance, Welding defects etc are the major causes for boiler tube failure.

If a boiler has to continue to function at a given/desired level of availability, its constituent items need some expected level of maintenance either by replacement or by repair.

**Previous status**

The analysis of causes for boiler tube failures in one of the thermal power stations shows that maximum failures were due to ash erosion with 43%, shop floor/site weld defects 16%, blockage of Reheater tubes 11%, steam erosion 10%, secondary air erosion 8%, attachment weld 6%, material defect 3% and creep failure 3%.

Except some stray cases, erosion failure is the significant cause of tube failure and is about 60% of the total failure.

The analysis of area wise tube failure indicates that about 40% of the failures occurred in super heater zone, 25% of the failures in water walls, 20% of the failures occurred in Economiser and remaining 15% failure occurred in reheater zone.

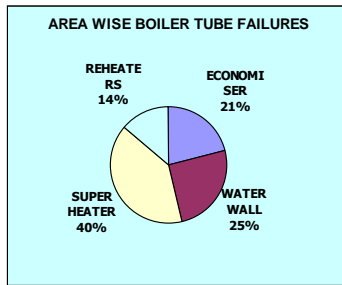

It was also observed that ash erosion in LTSH zone was more followed by ash erosion in economiser area. In water wall and wind box corner erosion is caused by secondary air leakage through expansion bellows.

### **General Measures for reducing tube failures**

The following are the general measures adopted in thermal power station to minimise the boiler tube failures:

- Thorough visual inspection of heating surfaces to identify eroded tube, deformation, swelling, bulging of tubes, etc.
- Shielding of tubes/bends in some identified, highly erosion prone areas to reduce erosion due to gas velocity in second pass.
- Tube thickness survey and thickness mapping in all identified areas. The general practice is to replace the eroded tubes with thickness reduced more than 25% of normal thickness.
- 100% welding inspection to ensure quality weld joints. Involvement of experienced IBR welders for pressure parts welding works.
- Emphasis to prevent flue gas/ash erosion. Erosion prone areas are extensively inspected and protected by providing shield / baffles, refractory etc.

### **Innovative preventive techniques to minimise tube failures**

The following preventive techniques have been adopted to minimize the boiler tube failures. These extensive preventive maintenance techniques, has resulted in the lowest boiler tube failure rate.

#### **1. Extensive Inspection of Pressure Parts**

- During annual overhaul, inspection of LTSH / ECO banks on left and right sides are being carried out after removing skin casing and cutting fins at places based on experience.



---

**BEST PRACTICES IN INDIAN POWER PLANTS**

---

- ECO coils are being lifted on both sides for inspection and to assess healthiness of tubes.
- Annual inspection of Platen super heaters and Re-heater bank bends are being done by arranging sky climber and platforms.
- Inspection of Roof tubes; Final super heater tubes and Super heater terminal tubes are being carried out by arranging multi tier platforms.

**2. Shielding Tubes at Critical Zones**

- To avoid ash erosion failures, shrouding/sacrificial shields are provided for water wall screen / extended water wall, Super heater screen tubes and extended steam cooled wall, LRSB's opening bends, LTSH terminal tubes / ECO hanger extreme end tubes above LTSH zone, LTSH coil straight tubes, ECO coil straight tubes and rear side straight tubes, LTSH supply tubes 90 deg. bends / offset bends, etc.
- Cassette baffles have been provided for bends of LTSH and ECO coil assembly to reduce erosion.

**3. Importance to Tube Alignment**

- The alignment of all coil assemblies and tubes in the horizontal pass and second pass are thoroughly checked.
- Stoppers (locking arrangement) to prevent movement of steam-cooled spacers are provided for Platen and Re-heater coil assemblies.
- Tubes that come out of connectors / distorted attachment can cause failure and hence are corrected during boiler overhaul.
- Vibration arrestors/clamps get deformed and make dent on tubes. They are being corrected as when noticed.

**4. Quality Welding**

- Welding electrodes are procured as per the recommendations of manufacturer.
- Radiography of weld joints is carried out by 100%.

**5. Maintenance of Flue gas Path**

- Thorough inspection of refractory is made to avoid flue gas diversion and impingement on bends and headers.
- Refractory linings are providing in areas of high ash erosion where shielding of tubes is difficult.

**6. Expert Analysis of Tube Failure**

- Failure analyses have been carried out through manufacturer's experts and metallurgical laboratories to identify root cause of tube failure as and when required.

**7. Post operational Two stage Chemical Cleaning**

- With continued operation over a period of time the magnetite layer grows in thickness due to slow corrosion of boiler steel tubes. Also carryovers from condensers and pre-boiler systems get deposited on the inner surface of boiler tubes where the heat transfer is high.

This growth of oxides and carryovers result in loss of heat transfer and accelerated corrosion of boiler tubes. This makes the boiler less efficient and more prone to localized heating. At times it may lead to tube failure. Therefore, importance is given for chemical cleaning of boilers.

**8. Installing Advanced Systems**

- Installation of the need based, selective wall blowing system called 'SMART Wall Blowing System'. this minimizes the erosion due to steam blowing in boiler tubes.
- An on-line, acoustic steam leakage detection system 'Sonic Tube Leakage Detection System' was installed to minimize occurrence of secondary damages during tube failure. This system helps in early detection of tube failure and reduces secondary damages of the surrounding tubes.

**Benefits**

In one of the units of the thermal power station the lowest boiler tube failure rate of 0.43 / year was achieved. Whereas the Indian average tube failure rate is about 3.36 failures / year.

Station boiler tube failure of 0.116 / 1000 hrs of operation is achieved.

**4.3.4. Case Study****LIFE EXTENSION OF COAL MILL GEAR-BOX LUBE OIL BY ELECTROSTATIC LIQUID CLEANING METHOD****Background**

Coal mills are one of the critical auxiliary equipment in power plants. The gearboxes in coal mills are lubricated by forced lubrication system. The grade of oil used is EP 320. Failure of mill gearbox components are costly affair leading to forced shutdown of the mill and consumption of high value imported spares.

**Previous status**

Due to gradual degradation of mill and gearbox sealing arrangement during service, considerable amount of fine coal dust entrains inside the gearbox and contaminates the oil. The effect of such contamination is improper lubrication of gearbox components (Gears and bearings) resulting in increased wear and premature failure of the components.

Necessity of frequent renewal of gearbox lubricating oil led to high consumption of oil and necessary disposal of hazardous waste oil.

**Project implemented**

Condition of gearbox lube oil has been improved and renewal of oil has been reduced considerably by :

- ❖ Use of modified gearbox sealing arrangement thereby reducing coal dust contamination.

### ***Manual on best practices in Indian Thermal Power Generating Units***

---

- ❖ Use of on-line side-stream filtration system working on electrostatic principle. The filter machine is capable of separating even very fine particle from oil and can salvage highly contaminated oil to working quality



**100 litre per hour On-line Electrostatic Liquid cleaning machine in operation**

#### **Benefits**

The following benefits have been achieved:

- ❖ Same charge of lubricating oil is now in service for a longer time; i.e. replacement & top-up of oil has reduced considerably and hence reduction of hazardous waste oil could be achieved
- ❖ Lubricating oil is in better operating condition; wear of gearbox components has come down.

The following table indicates reduction in oil replacement and oil consumption including top-up:

<b>Financial year</b>	<b>2002-2003</b>	<b>2003-2004</b>	<b>2004-2005</b>
Total number of gearbox oil replacement in all mills	32	19	6
Gearbox oil procured (Litres)	23,520	12,600	3,570

#### **Financial analysis**

Cost of Two nos. Liquid cleaners are Rs. 4 Lakhs.

Cost of of Gearbox Oil – Rs. 60/- per litre

	<b>2002-03 to 2003-04</b>	<b>2003-04 to 2004-05</b>
Oil consumption reduction (litres)	10,920	9,030
Cost Savings (Rupees lakhs)	6.55	5.42

#### **4.3.5. Case Study**

##### **HIGH CONCENTRATION SLURRY SYSTEM FOR ASH HANDLING**

###### **Background**

The Indian coal has very high ash content. The ash content in the coal is in the range of 35-40%. This leads to increased production of ash and serious problems related to evacuation of the same. Some times, this also leads to loss of generation on account of inadequate ash evacuation.

The conventional method of ash evacuation through dumpers was not only costly but also not dependable. This also requires huge ash dykes for disposal of ash. The latest trend is utilizing “High concentration slurry system” for reliable and efficient ash evacuation.

###### **Previous status**

Initially the entire amount of ash was evacuated in moist condition through dumpers for which a considerable amount of payment had to be made to the ash contractors. Subsequently new avenues for ash utilisation were introduced in the form of Barges and Tankers which resulted in better utilization of dry Fly ash in Cement Industries as well reduced cost of evacuation.

However with the increased usage of inferior grade coal the large quantity of ash produced posed a major threat to the increasing demand of power generation.

###### **Project implemented**

HCSS is a new concept in the field of effective handling and utilization of fly ash. It involves transportation of fly ash in the form of slurry of homogeneous nature at a specific concentration (58% to 64% solid concentration). As the ash slurry is used at a specific concentration and also it is a homogeneous mix, it maximises the usage of the land area and takes care of the environmental consequences otherwise likely in way of dust formation and contamination caused by ash laden effluent.

The slurry is prepared by the Dosing and Mixing unit, conditioned in the Agitated Retention Tank and then pumped to the site at a distance of around 2.5 kms. through a pipeline by GEHO pump.

At the mound area the slurry is discharged at a time from two flexible heliflex hoses connected to the main line bus with the help of a 'Y'- piece and gets spread over a very small area.

The flow stops within a run of around 30 mts. only under a natural angle of repose due to the consistency of the slurry. In this way a sloped surface is formed. The homogeneous composition of the slurry ensures no water is released when the slurry is discharged at the mound area.

This thick slurry transportation system was adopted by plant for transporting fly ash and making a number of mounds/ hillocks with a view to finally vegetate them to convert the area into a beautiful resort on the bank of the river Hoogly.

The consistency of the slurry produced by this system is such that it produces no effluent and there is no leaching effect and so hard solid mounds can be formed up to a height of 30 meters.

The complete system engineering, supply of equipment and erection are by M/s McNally Bharat (India) Ltd jointly with M/s WEIR, Netherlands (formerly M/s Envirotech of Netherlands). The plant has received a grant of appx Rs 2 Crores from the Government of Netherlands for using this eco friendly technology in India.

Single line diagram of the system is as follows :

**SINGLE LINE DIAGRAM OF HIGH CONCENTRATION  
ASH SLURRY HANDLING SYSTEM**

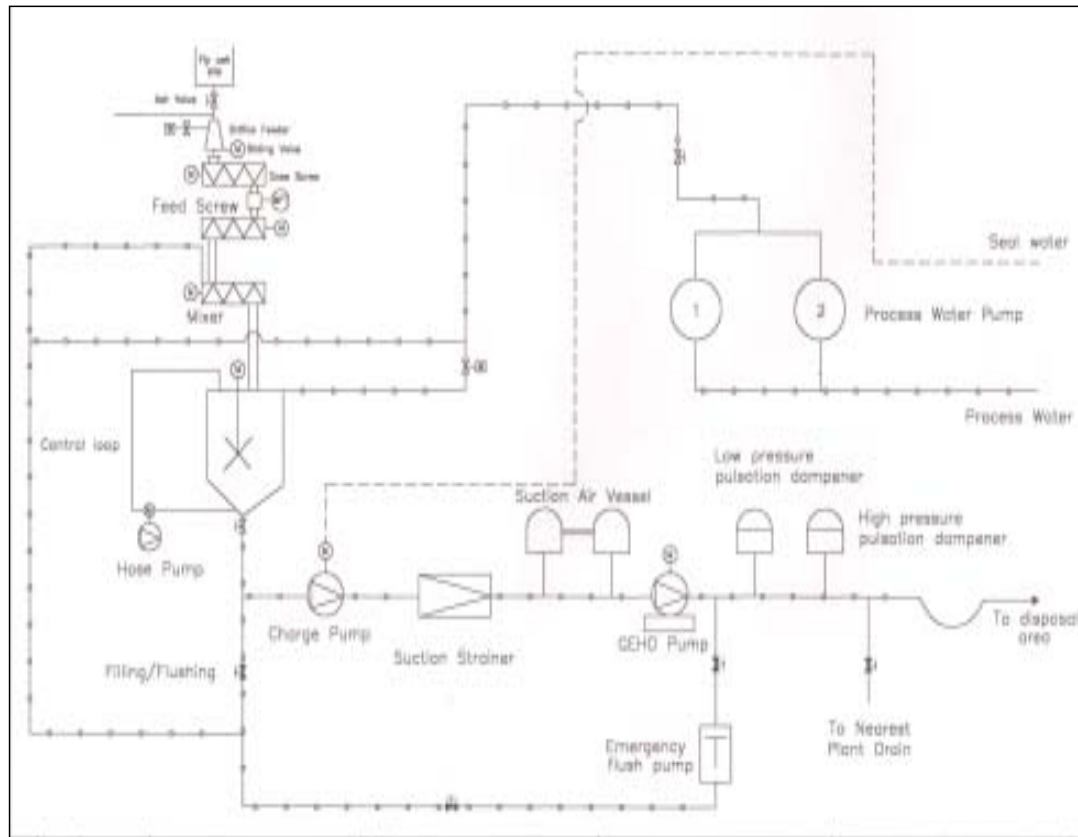

**Formation of Ash Hillock**



**Benefits**

High Concentration Slurry system has got following benefits over conventional methods of ash evacuation.

- ❖ Much superior environment protection.
- ❖ Much higher tonnage per hectare of land due to high stack height and dense deposit.
- ❖ Low cost per tonne of ash removal.
- ❖ Better utilization of fly ash.
- ❖ No fugitive emission

**4.3.6. Case Study****REDUCTION OF 500 MW UNIT START UP TIME AT TROMBAY THERMAL STATION, MUMBAI****Background**

Ensuring uninterrupted power supply to consumers is a challenge for staff in every power station. Reducing / eliminating number of shutdowns & their duration is therefore an important measure. Shutdowns are due to planned outages (taken for planned/preventive maintenance activities on a scheduled basis) or forced outages (unit trippings or stoppages due to various faults). Total shut down time is spent in two major activities. Finding / correcting the fault and then restarting the unit. Time required for finding and correcting the fault depends on type of fault & is therefore a variable. However startup time can be controlled.

During startup period, fuel is used to raise steam pressure & temperature without electrical generation. Therefore when startup time is minimised, it can help in not only early restoration of power supply to consumers but also savings on account of startup fuel. Cost of start up is Rs 3.5 lakhs per hr (considering oil as startup fuel) which is substantial potential for saving.

Three types of Unit startup are generally considered as follows –



**Hot Start—:** In this case, Boiler and Turbine are hot at the time of start up. Generally boiler & turbine temperatures match with HP-LP bypass operation & hence startup is quick.

**Warm Start—:** In this case, shutdown is for few hours /days (6-8 hours to 2-3 days.) Turbine is warm (temperature in the range of 250 to 350C) Boiler components are warm or cold. Hence it takes relatively more time for startup to raise steam pressure/temperature to bring to a matching level of turbine.

**Cold Start—:** Such startups are encountered after major planned/forced outage of the unit of longer duration. In this case boiler as well as turbine is nearly at room temperature. Boiler pressure & temperatures need to be built up slowly .It takes longer time as start up of many auxiliaries is also required.

At Trombay Thermal station, special attention is given to minimize startup time in all three cases mentioned above. This paper gives details of such practice followed at Trombay Thermal Power Station.

### **Previous Status**

Startup time is considered between boiler lit up & synchronization. Earlier statistics show that time taken for hot, warm & cold starts was as follows:

**Table 1**

<b>Type of start up</b>	<b>Time taken</b>
Cold start	13.22 hrs.
Warm start	2.9 hrs
Hot start	1.22 hrs

### **Project implementation & Challenges Faced**

#### **1. Planning & coordination**

Startup is a complex activity because it involves interactions of various processes & persons from all disciplines/functions at thermal station. It involves both –

### ***Manual on best practices in Indian Thermal Power Generating Units***

---

sequential & parallel activities .Although the process is standardized in any power station, the time required may increase due to unforeseen events or lack of planning & coordination. A typical startup includes detailed planning giving meticulous attention to the following:

- ❖ Clearance of equipment for running from all concerned depts.
- ❖ Availability of all interlocks & controls
- ❖ Correct line up of equipment & systems
- ❖ House keeping of equipment & surroundings
- ❖ Safety of equipment & personnel
- ❖ Alertness & Frequent rounds to detect any leaks & to guard against any unsafe operations
- ❖ Correct communication & feedback
- ❖ Critical monitoring of each equipment

When equipment is being started, it is subjected to operating conditions which are different from its normal stable operating conditions .Therefore to ensure a smooth & safe startup is an arduous task.

Over & above this, if we have to minimize startup time it requires lot more attention & coordination to avoid time wasters.

Meeting time deadlines include detailed scheduling focused on:

- Hourly planning to ensure equipment is cleared for operation as per the date & time decided after mutual agreement between working parties
- Detailed recommissioning schedule drawn up with assigned responsibilities
- Identifying critical activities & ensuring that all resources are mobilized to meet the time deadlines.

At first glance although it may look tough target but it is not impossible. What is most important is spirit of cooperation & understanding mutual needs & extending a helping hand to others to save overall time. It is this commitment to

---

**BEST PRACTICES IN INDIAN POWER PLANTS**

---

common goal that has helped Trombay Thermal station to minimize not only the startup time but to reach a benchmark standard of overhaul time of 500 MW units in India (22 days)

## 2. Learning

Learning from past experience & implementing changes is a key to success. Various activities of startup in the past were analyzed from the point of view potential to save time. Major milestones/nodal points were identified on critical path. Parallel activities were monitored & expedited to meet prerequisites for starting serial activities at every nodal point. Some of the activities were advanced or rescheduled/ parallely done to save time in cold start up.

It includes:

- Preboiler flushing to save time in silica purging
- Deferring main turbine oil tank cleaning to once in four years.
- Advancing interlocks & alarm checks.

A typical time saving in start up after major overhaul observed is given in following table.

**Table 2**

<b>Activity</b>	<b>Time saving due to advanced actions</b>
Preboiler flushing Turbine oil flushing Interlock Tests	2hrs 8 min
Boiler lit up HP-LP bypass operation Turbine rolling Electrical tests & synchronising	2 hrs 14 min
Total	4 hrs 22 min

### Benefits achieved

Figures 1to 3 show the improvement brought about in Startup time of these units.

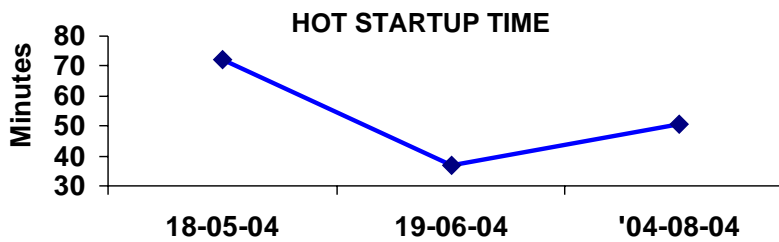
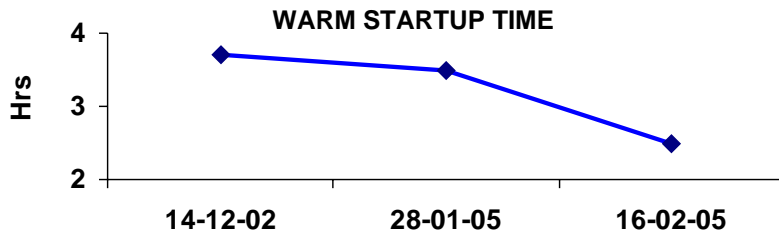
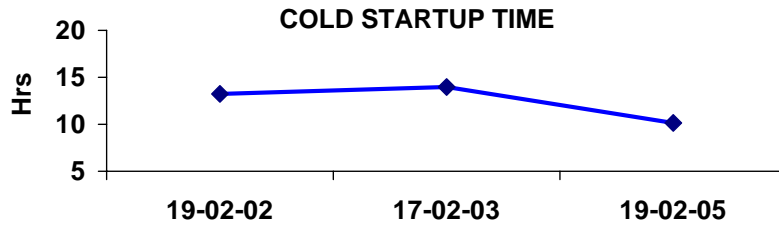

### Financial Analysis

Table 3 shows comparison done with previous best timings for each type of Startup & respective saving in terms of time & startup cost (fuel cost + aux consumption)

**Table 3**

<b>500 MW unit start up time improvement</b>				
	<b>Date</b>	<b>Duration</b>	<b>Time Saving</b>	<b>Estimated saving Rs. in Lakhs</b>
1. Warm Start	16-02-05 02-05-04	2 Hr 25M 2Hr 52M	27 Min.	1.6
2. Cold Start	19-02-05 19-02-02	10Hr 05M 13 Hr 13 M	3Hrs 8Min.	10.5
3. Hot Start	19-06-04 18-05-04	37 min. 1Hr 12M	35 Min.	1.8

With doubling of oil prices in 2006, the savings would be doubled in present operating condition. Such savings both in terms of time & cost ultimately are passed on & benefit the consumer.

The time required for startups as given above is one of the minimum when we compared with similar units at other places in India. Absolute comparison may be difficult as there could be large variations in systems & procedures at each power station .In January 2005, NTPC team visited Trombay Thermal station. Data was exchanged with them for benchmarking.

Reducing startup time without compromising on quality & safety of operations, can be thus taken as an opportunity for improvement & benchmarking.

**4.3.7. Case Study****INNOVATIVE METHODS OF REDUCING CAPITAL OVERHAUL TIME**

**Prior Status**  
Outage duration in previous overhauls

Year	500 MW -Unit 5	500 MW -Unit 6
1999	38 days : LP - Gen	43 Days: LP -Gen
2001	–	36 Days: IP Turbine
2002	41 Days: HP Turbine	–
2003	–	34 Days: LP Turbine

**Prior Status**  
Outage duration in previous overhauls

Year	500 MW -Unit 5	500 MW -Unit 6
1999	38 days : LP - Gen	43 Days: LP -Gen
2001	–	36 Days: IP Turbine
2002	41 Days: HP Turbine	–
2003	–	34 Days: LP Turbine

## Unit 5 Jan 2004 Overhaul

### **Job-scope:**

#### **A. Turbine**

- 1. HP Module replacement**
- 2. LP Turbine overhaul with de-blading of free standing blades and MPI.**

OEM's BHEL and Siemens indicated a duration of 39 Days after detailed discussions with TPC senior management.

#### **B. Boiler re-certification**

## Unit 6 Jan 2005 Overhaul

### **Job-scope:**

#### **A. Turbine**

- 1. HP Module overhaul**
- 2. IP Module Overhaul**
- 3. Generator major overhaul with rotor thread out.**

#### **B. Boiler re-certification with RLA**

## The Obligation

25 days outage duration to meet ABP generation target.

## The Challenge

Completion of outage in 25 days:

1. OEM's not ready to take the challenge.
2. No reduction in scope possible to ensure reliability of machine

## Team Based Approach

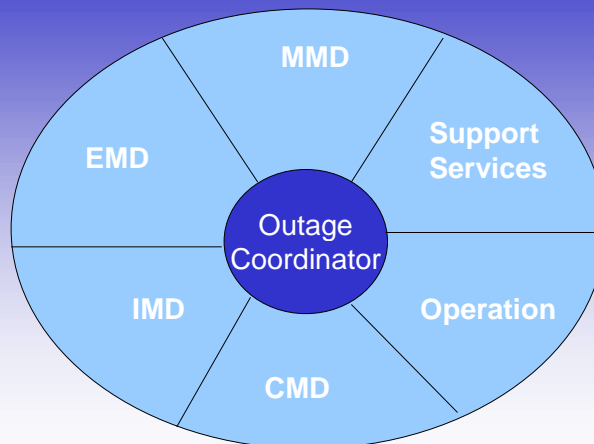

**Empowerment by Senior Management**



## Team Based Approach

1. Finalize scope of work.
2. Preparing integrated micro plan on hourly basis.
3. Identification of constraints and concerns
4. Resource planning

## Outage Planning

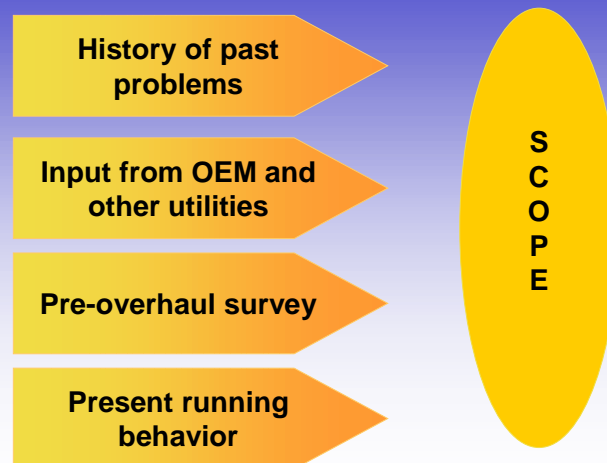

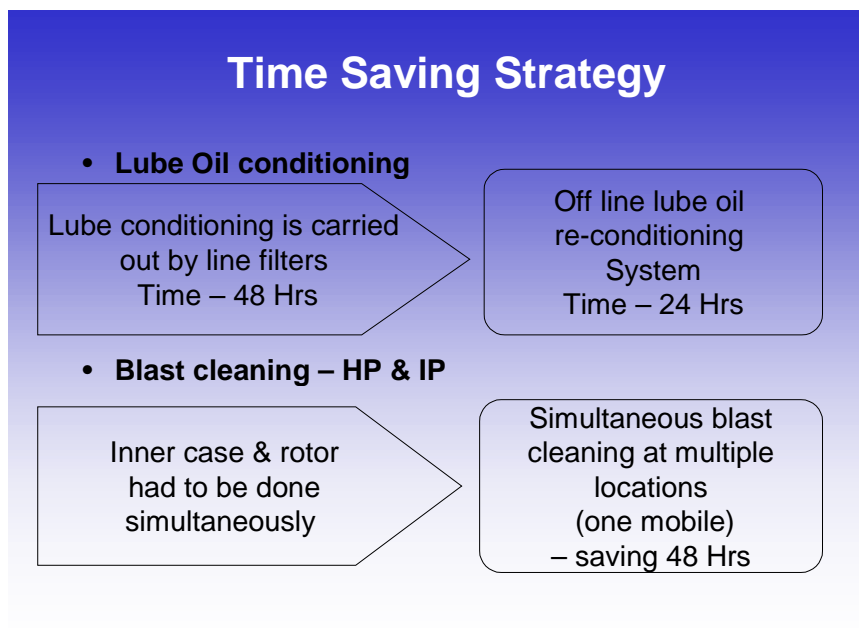
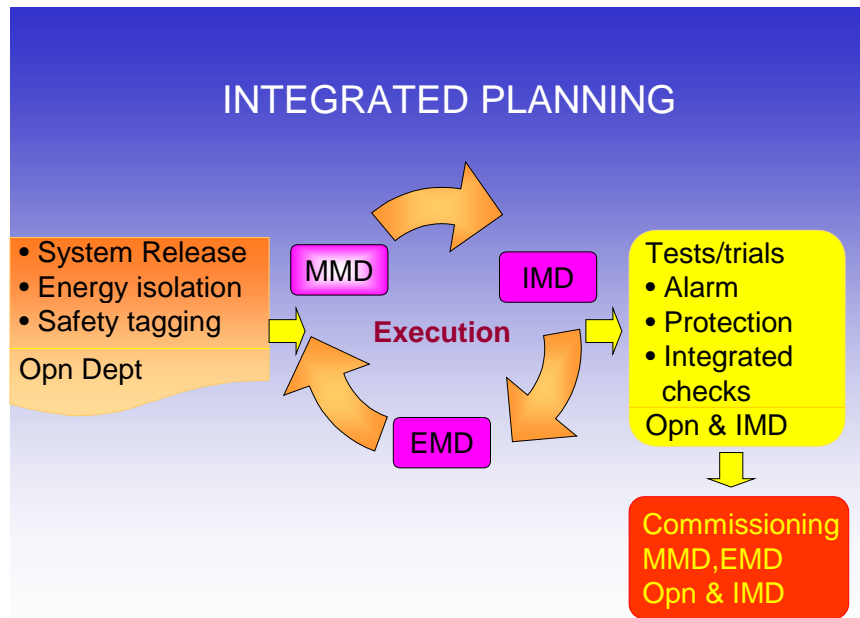

## Time Saving Strategy

- **Air pre-heater**

All elements of the air pre-heaters baskets (1056nos) were required to be removed for replacement / hydro jet cleaning

Extension of platform and handling facility created for simultaneous work on both the air pre-heaters

- **Feed Cycle**

Work on Equipment / system not requiring outage

- Plate heat exchangers
- Cooling Water Pump
- Replacement piping kept ready

## Time Saving Strategy

- **Turbine bearings**

Torus piece and cylindrical support matching takes around 1 week

Spare bearing shell CNC machined along with torus piece and support kept ready for replacement

- **Turbine valves**

Replacement of spindle / valve cone of turbine stop / control valves – time consuming assembly

Spare spindle – valve cone assembly kept ready before overhaul based on pre-overhaul survey

## Time Saving Strategy

- **Boiler tube thickness measurement**

Economizer inlet stub thickness measurement needed to be done in view of previous failure.

Conventional UT would have taken 4 days. LFET adopted for thickness profile, completed in 2 days.

## Resource Planning

- **Manpower**
  - Discussion with service provider and finalizing area wise work crew for round the clock working
- **Special tools / machines**
  - Design and fabrication of fixture for drilling hole in HP inlet flange face
  - Design and fabrication of fixture for IP rotor balancing
- **Expertise**
  - Services of OEM Expatriate for in-situ balancing
  - Services of retired OEM experts

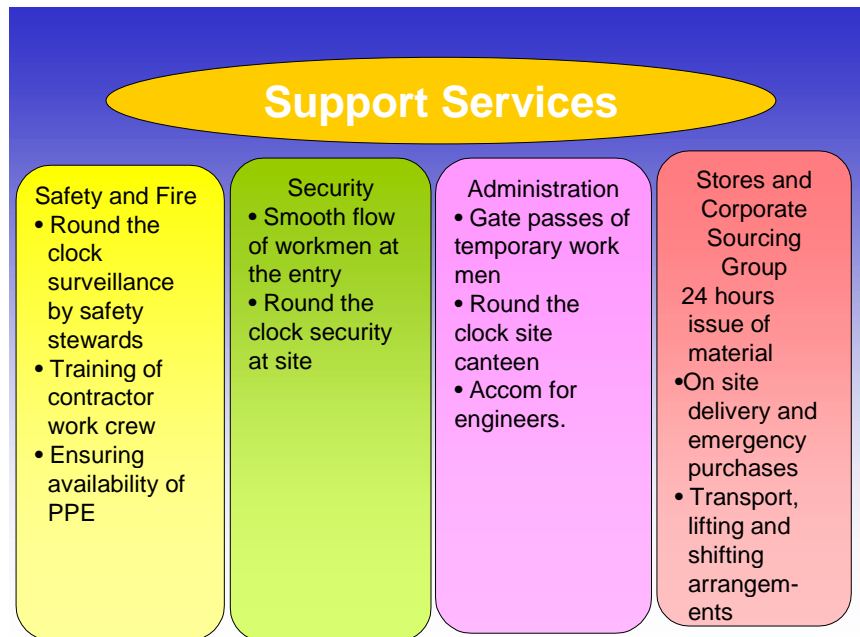

### Milestones based review

- Monitoring of critical activities impacting outage schedule.
- Monitoring start of activity which is equally important.

Day	Date	UNIT 5 OUTAGE MILESTONES	Remarks
1	29-01-06	HT/Regulation	Completed
		NO Electric oil cut	Completed
		Turbine fuel cutting	As planned
2	30-01-06	Steam/Regulator approach to low pressure	
		Boiler Dry Gas Test	Completed
		SHROFF EA lowering	Completed
		Oil escape LP filter	Completed
		Start generator disconnection	Completed
		FO air valve off air	Completed
		Safety valve overhaul start	Completed
		Start CF System	Completed
		Start disconnection of Turbine valves	Started on schedule
		3	31-01-06
Through out Generator rotor	Completed		
Stoppage of CW, Aux. Feed water system	Stopped on schedule		
ED separator installation start	Started on schedule		
Enter RLA work start	Started on schedule		
4	01-02-06	Boiler washing complete	Completed
		CW in charging & de-aerating	Completed
		Ductile pipe verification start	Started
		Start De-aerator inspection and repair	Started
		ACVF system stop	Stopped on schedule
		Review of turbine condition	Completed
		Inspection, repair of pressure parts start	Started on schedule
		Boiler basket removal start	Started on schedule
5	02-02-06	Painting and stainer work start	Started on schedule
		Exp. area scaffolding complete	Completed on 04.02.2006
		Flue gas cleaning start	Started on schedule
		Condenser tube cleaning start	Started on schedule
		CRN Turbine inspection	Completed

## Plant up-keep and housekeeping

VP's instruction to commissioning group, " No equipment to be taken in service till the equipment area is cleaned"

18 2 2004

## Turbine Highlights Unit 6 2005

Turbine Cooling	69 Hours.
HP lift off	5 <sup>th</sup> Day
IP Rotor lift off	7 <sup>th</sup> Day
IP assembly	11 <sup>th</sup> Day
HP installation	12 <sup>th</sup> Day.
Assembly of rotors	17 <sup>th</sup> Day.
Insulation of HP & IP	20 <sup>th</sup> Day
Oil flushing and machine on TG	21 <sup>st</sup> Day.
Unit Synchronization	22 <sup>nd</sup> Day.

## Outage Duration

Unit 5 Jan 2004 : 25 Days

Unit 6 Jan 2005 : 22 Days

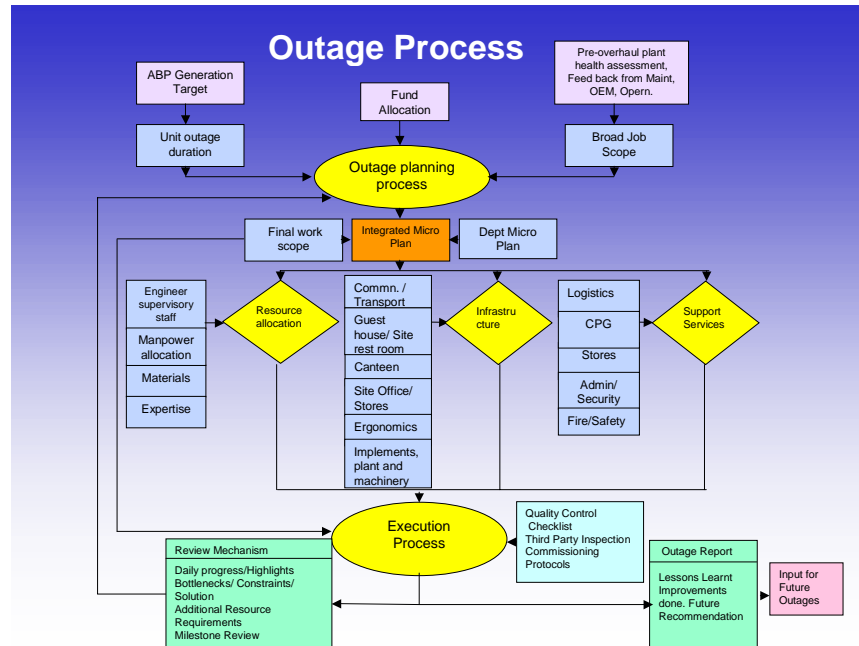

#### 4.3.8. Case study

### REPLACEMENT OF AERO DERIVATIVE TURBINE IN VERY MINIMAL TIME DURATION

#### Background

GMR Energy limited is a 220 MW Barge mounted combined cycle power plant with power plant with 4 X 46.5 MW GE aero derivative Gas Turbine and 1 X 54.5 MW steam turbine.

The Gas Turbines uses Naphtha as the fuel and as per GE recommendations the hot gas path components has to be replaced in every 12,500 hours of operation. For replacing the hot gas path components the Engine has to be removed from the enclosure and work has to be carried out on a special maintenance dolly. To minimize the number of outage days, the plant has a spare Engine which will be replaced with any of the Engine which is due for maintenance.



---

**BEST PRACTICES IN INDIAN POWER PLANTS**

---

The Gas Turbine is a twin shaft construction (HP and LP shaft rotating at different speeds) encased in a single casing. The Net weight of the GT is 7.5 Tons and it is enclosed in a sound proof enclosure and it is also capable of taking any sort of impact resulting from engine failure. The enclosure also supports the variable bleed duct, and compartment ventilation duct. The total enclosure with Engine mounting supports is fixed to the barge with anti vibration pads.

The Engine is supported at the front end (fixed point) on a bolted stool with trunion support, and aft end is supported through flexible taper supports with trunion supports. The LP shaft is coupled at the cold end to gear box with a flexible coupling shaft. The exhaust of the GT is guided to Once through Steam generator through an exhaust diffuser and a bellow assembly. The bleed duct is connected through a duct and its exhaust is taken out to the atmosphere out side the enclosure.

Two numbers of 10 T EOT crane with bus bar for long travel are installed on the barge, for four GT'S maintenance. One crane caters two GT'S maintenance, and common maintenance bay is there for two Engines.

The spare Engine is normally kept in the work shop in a nitrogen sealed container. The Barge is moored in a back water river from sea, with ramp connecting the jetty to take care of the tide variation.

**Previous Status**

The first Engine replacement on the barge at site was done during commissioning in September 2001 by IHI (Ishikawa harijma Heavy industries Tokyo Japan) who is the packager for GE LM 6000 aero derivative gas turbine when one of the Engine failed due to control system problem. IHI took 12 days for Engine replacement.

Aero derivative Engine removal and assembly on a barge is a specialized job and experts where called for each area for job execution.

Special tools for dismantling the Engine and enclosures where not available.

The EOT crane Bus Bar was not of single piece, and brushes where guided in an enclosed case of bus bar, which gave problem of dislocating at the joints during crane movement, this resulted in loss of time for crane rectification.

Job planning and resources mobilization was not adequate which resulted in jobs happening in series.

Spares and consumables needed for Engine replacement where not envisaged resulted in time delays in Engine replacement.

In May 2002 One Engine needed maintenance which was taken up in house with out packagers help and GEL did the job in four days.

### **Project Implemented**

#### **1. EOT crane bus bar arrangement modification.**

The criticality of crane operation was studied and modification was done in the bus bar system to over come the problem.

The Bus bar was replaced with flexible collapsible power cable with suitable sliding arrangement for the cable to move along with the trolley.

#### **2. Special tools and fixtures.**

The following special tool sand fixtures where made to reduce the time consumption.

Special tools for dismantling and assembly for coupling bolts, Engine Mount support and trunions dismantling and assembly.

LP coupling support fixture after de coupling.

Special fixtures for bellows in exhaust and duct compression.

Special fixture for compressing the coupling flexible membranes to free the coupling from LP shaft coupling spigot.

#### **3. Spares and consumables.**

Spares and consumables required during Engine replacement was identified and adequate spare mobilized.

#### **4. Training and planning**

In house Engineer identified and Job planning was done and training was given during second Engine replacement. Work force for assisting in carrying out Engine replacement where also trained.

Activities involved in Engine replacement where listed parallel activities identified and detailed program made to carry out the Engine replacement.

##### **Challenges faced while implementation**

The major challenge face by plant team was to do the replacement in minimum possible time without compromising on safety of equipment and persons.

##### **Benefits**

This has resulted in reducing the downtime of gas turbine and improvement in plant availability

##### **Financial analysis**

Improvement in plant availability.

#### **4.3.9. Case study**

##### **IMPLEMENTATION OF LOTO – LOCKOUT AND TAG OUT SYSTEM**

###### **Background:**

Plant started commercial operation from June 2001. Initially PTW system was in practice for taking care of isolations and safety of persons working and equipments. PTW was generated manually and only the tag out system was available. To ensure 100% safety of the man and machine and also as a part of continual improvement many changes have been carried out in PTW system and the lock out and tag out system was introduced.

###### **Previous Status**

Plant was operating with only tag out system with manually generated permits for cold work, hot work and confined space works.

**Project Implemented**

The permit to work system was integrated with plant computerized maintenance management system. The plant maintenance management system generates work order based on defects in the plant and preventive maintenance schedules. After authorization of work order permit to work is issued by operations department through the maintenance management system. The system has provision of issuing all types of permits for cold work, hot work and confined space work. The system has provision for cross linking of permits and easy tracking of pending permits. The system is normalized after the job completion and permit closure in the system after necessary trial and inspection from operation department. As a part of continual improvement lock out system is also implemented.

Lock-out Tag-out system is a means of positive electrical isolation that is done to the equipment under permit. Locks are provided either at the motor control center (MCC) or the circuit breaker panel (C.B panel). This lockout is applicable to electrical isolation only.

A lock out board having lock out bolts is kept in the control room from where the authorized person issues the permit. Each permit will have a specific lock out bolt number associated with it. The keys of the locks provided for electrical isolation are placed in the lock out bolt. The lock out bolt will be locked by the concerned departments and the authorized person issuing the permit. The keys for electrical isolation can be removed only when the person responsible for job execution surrender the keys for lock out bolt. The surrendered key and the key with permit issuing person have to be used jointly to remove the keys used to normalize the isolation. This ensures the concurrence of both the parties responsible for job execution and isolation to normalize the system.

**Challenges faced while implementation**

The challenge faced was to initiate the process. As the plant team is highly motivated for continual improvements the implementation of system was not a major issue, once the concept was formulated. The system before implementation was discussed

with the team with all the logistics involved. All necessary recommendation were given due consideration in implementing the system. As all the persons were involved in formulating the system the implementation was smooth.

**Benefits**

Accident free work environment. Zero accident in plant till date after 5 years of operation.

**Financial analysis**

No man hours lost due to accident and no production loss due to the same.

**4.3.10. Case Study****MINIMISATION OF COLD START UP AND SHUT DOWN TIME****Previous Status**

GMR Energy limited is a 220 MW Barge mounted combined cycle power plant with power plant with 4 X 46.5 MW GE aero derivative Gas Turbine and 1 X 54.5 MW steam turbine.

The plant startup time was 9 hrs for cold condition, 5 hrs for warm start and 3hrs 50min for hot start. The plant startup heat rate was 2300 Kcal / kwh for coming to 220 MW from 0 MW. Will all the modification project implementation the plant startup time is 6hrs for cold condition, 4 hrs for warm condition and 2 hrs 9 min for hot condition. The startup heat rate is presently 2150 Kcal/Kwh. The efforts are still on to achieve 1hrs 30min startup time for hot condition by this year. Similarly plant shutdown time was optimized from 1hr 30min to 45min. Plant shutdown heat rate was optimized and reduced from 2500 Kcal/Kwh to 2350 Kcal/Kwh. With all the improvements the plant steady state heat rate has improved by 40 Kcal/Kwh.

**Project Implemented**

The startup time reduction was achieved in three steps in order to achieve combined cycle plant start up in minimum time:

***Manual on best practices in Indian Thermal Power Generating Units***

---

1. GT start up time reduction: Gas turbine startup time was 23 minutes earlier which was reduced to 14 minutes by incorporating following changes –
  - a. Gas turbine has a 10 minutes pause at motoring speed to purge the exhaust gases in the exhaust before fuel ignition. The pause time was on higher side as required for 5 times exchange of air. With discussion with OEM the purge time was reduced to 7 minutes.
  - b. Gas turbine has a 5 minutes pause at core idle speed for stabilizing the parameters. After study by plant team and with concurrence of OEM the pause time was reduced to 2 minutes
  - c. Gas turbine has 5 minutes warm up pause at full speed no load. This was also reduced to 2 minutes after concurrence with OEM.
2. Gas turbine loading ramp rate was 4.8 MW/min earlier and machine took 10 minutes approximately to come to full load. With discussions with OEM the loading ramp rate was improved to 8 MW/min and machine now takes approximately 5 to 6 minutes to load up to full capacity.
3. OTSG start up time reduction: Once through steam generator startup as per the original design used to take 1hrs before it can be lined up to STG for power generation. Start up is done in various steps like flow increase to minimum flow, pausing for steam line and bypass station warm up, pausing for condenser vacuum buildup and pausing for heat sink removal from OTSG. This takes approximately 1 hrs to get stabilized steam parameters before lining up steam to STG for power generation. The original design was to start 1 OTSG at a time. Therefore approximately 3 and half hours were required for OTSG startup. Now with the modifications logics were developed to start OTSG simultaneously and reducing the startup time. Heat sink removal waiting time which was approximately 45 minutes was also removed by incorporating various logic changes after discussion with OEM. With all the changes implemented OTSG can now be started in 20 to 15 minutes before lining up to steam turbine for power generation. Following changes were done to achieve the same:

**BEST PRACTICES IN INDIAN POWER PLANTS**

---

- a. Simultaneous start up of OTSG was enabled. 2 OTSG can now be started together in one bypass or in different bypass.
  - b. OTSG can now be line up to STG after it achieved 110% full load flow and waiting for heat sink removal was removed. The condition now introduced is full load flow with steam pressure greater than the steam header pressure by 1 bar.
  - c. Initially HP circuit has to be started and after 10 minute of HP circuit reaching feed forward mode (condition of stability) LP circuit could be started. Now with the logic changes done LP circuit can be started immediately after HPO circuit reaches feed forward mode. This has resulted in saving of 10 minutes for each LP circuit startup.
  - d. HP circuit ramp up rate for feed water flow was increased from 6% of full load flow to 8% of full load flow.
  - e. HP circuit steam flow required for steam line heating is increased to 6.5 TPH from 4.5 TPH for faster line warming up. Similarly for LP circuit also it was increased to 4.5 TPH from 2.5 TPH.
  - f. Additional drain lines were provided by using the existing provisions for faster line warm up.
  - g. Interconnection of HP and LP steam line for reducing the LP circuit warm up time is being done through all necessary protections.
  - h. One-minute time delay is introduced for HP & LP high flow trip to avoid trips during start up.
4. STG start up time reduction: STG startup includes warming up of steam line, vacuum buildup, heating up of valve chest, rolling up the turbine with necessary soaking and synchronization. The line heating time and rolling time mainly depends on condition of steam turbine (temperature) prior to start up, which is classified as cold, warm and hot start up modes. Following measures were taken to optimize the above:

***Manual on best practices in Indian Thermal Power Generating Units***

---

- a. Logic modifications were done to start up vacuum system before main steam line temperature reached 250 deg.c by starting vacuum pump. This has resulted in earlier build up of vacuum in condenser and reduction in start up time. Earlier vacuum pump was started after steam line temperature reaches 250 deg.c.
- b. Hot start up mode conditions were changed from 330 deg.c to 320 deg.c by logic modification to get a faster start up and higher loading ramp rate by 10 deg.c.
- c. STG warm start up loading ramp rate was increased from 20 MW/hrs to 30 MW/hr.
- d. STG HP high temperature trip set point was increased from 431 deg.c to 444 deg.c to take care of steam temperature fluctuation during startup.
- e. A new gland steam control valve was installed to avoid manual intervention in gland steam pressure control during startup.
- f. STG padded insulation was changed to solid spray insulation. With this heat is conserved in STG and machine remains in hot start up mode even after 12 hours of shut down. This time was 6 hours earlier with padded insulation.
- g. Control valve installed for steam ejector motive steam pressure control to avoid manual intervention.
- h. By pass station control the OTSG start up steam pressure ramp rate. The ramp rates were 0.8 bar/min for cold startup, 1.4 bar/min for hot and warm start up. These were increased to 2 bar/min for hot and warm start which has allowed us to get required pressure early
- i. HP ESV opening condition was changed from 33 bar steam pressure to 25 bar. This has enabled in opening ESV earlier and faster heat up of control valves.



- j. Provision of hogging ejector to reduce vacuum build up time in condenser by 10 minutes is being implemented. This will also reduce the steam line warm up time.
- 5. Chiller integration carried out to facilitate chiller start-up from control room. This has resulted in better monitoring and faster start up of chillers from control room during plant start up.
- 6. Provision of on line monitoring of plant start up and shut down installed to have a better control over plant start up activities.

**Challenges faced while implementation:**

OEM approval was main concerned. After lots of experiments and studies back up was prepared and was given to OEM for approval. This was one of the most tedious and challenging processes.

**Benefits**

Results in reduction of start up and shut down time as it is most applicable to our plant as we are considered as peaking plant for load dispatch. We are able to run for full load dispatch for more time which has resulted in improvisation of heat rate.

Customer satisfaction index has further improved mainly KPTCL with above project implementations we considered more reliable and less time is taken to come to full load dispatch conditions.

**Financial analysis:**

Time saved in reaching full load steady state operation 3 hrs

Plant now runs at steady state heat rate for extra 3 hrs as against startup heat rate 2150 Kcal/Kwh.

Saving in heat rate is 240 Kcal/Kwh for 3hrs @ 220MW

Considering naphtha gross calorific value as 11340 Kcal/Kg and present cost of naphtha to plant of Rs 33.4 / kg, saving is approximately Rs 4.66 Lacs per start up.



## **4.4. ENVIRONMENT IMPROVEMENT**



#### 4.4.1. Case study

### **FLUE GAS CONDITIONING BY AUTO CONTROLLED DOSING OF AMMONIA GAS AT ESP INLET AND IMPROVING PERFORMANCE OF ESP**

#### **Background**



In power plants the statutory limit for maintaining the SPM level is 150 mg/Nm<sup>3</sup>. With electro static precipitation SPM in flue gas was maintained at around 140 mg/Nm<sup>3</sup>. For further reducing the SPM level, various improvement works were carried out such as modification of rapping timer logic and sequence, modification of ESP internals and tuning of ESP field controllers. These resulted in reduction of SPM level to around 100 mg/Nm<sup>3</sup>. However to further reduce SPM level, flue gas conditioning with ammonia dosing was found to be the most suitable solution.

#### **Principle of the process**

Ammonia gas lowers the ash resistivity of the ash particles and thereby enhances collection in the ESP field. Also ammonia increases ash cohesivity and agglomeration and thus increases the effective ash particle size. Larger ash particle size results in better collection efficiency.

#### **Project implemented**

- ❖ The ammonia dosing system includes ammonia cylinders, Masibus controller, control panel, manifold, volume flow meter, pressure gauges, isolating valves and carrier air bus.
- ❖ Process logic is incorporated at Fly ash PLC.

- ❖ Stack SPM signal is brought from DCS to a Masibus controller
  - ❖ The Masibus controller generates three contact outputs with three set points (corresponding to three levels of dosing), which activates soft timers in PLC. This in turn operates three corresponding solenoid valves in the auto control panel.
  - ❖ Flow regulator downstream of each solenoid valve is set to 20 LPM flow corresponding to 1 ppm ammonia concentration in flue gas.
  - ❖ The JB, control panel and other hardware are housed in a concrete Ammonia Dosing room.
  - ❖ Metered ammonia from the control panel is led via carrier air bus to ESP inlet.
- The schematic diagram of the ammonia injection system is given below.

**Schematic diagram of the Ammonia injection system**

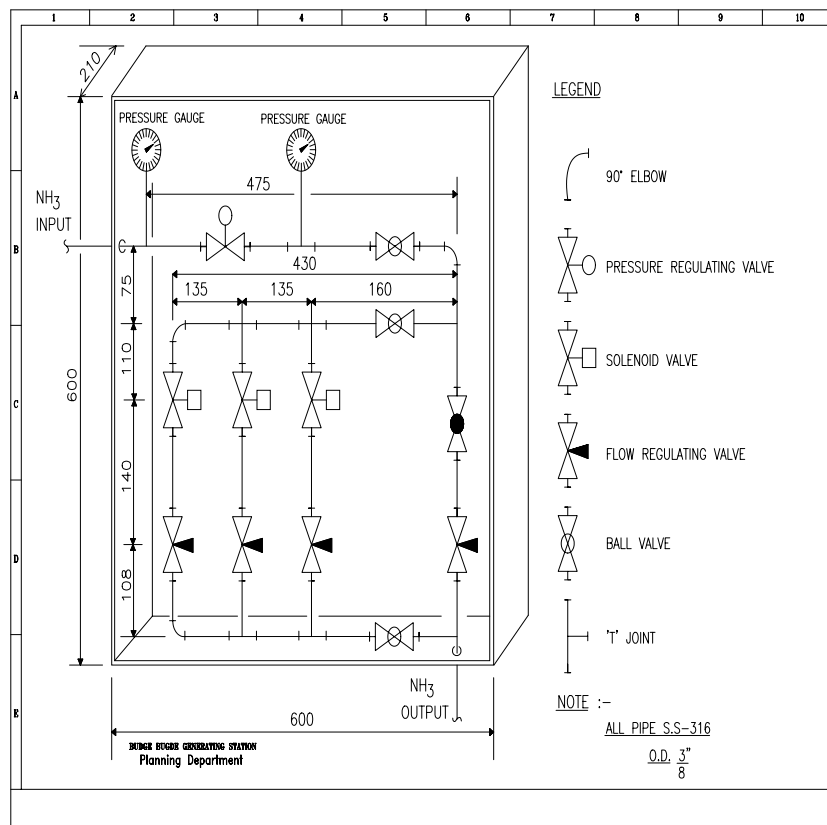

**Benefits**

Dosing of ammonia gas at ESP inlet started from the month of February 2004 in both Units. Auto controlled dosing of ammonia started from November 2004.

The following table and graph illustrates the remarkable improvement in Stack emission level.

Month	Opacity (mg/Nm <sup>3</sup> )	
	Unit - 1	Unit - 2
Sep-03	133	147
Oct-03	121	142
Nov-03	131	139
Dec-03	145	140
Feb-04	107	112
Mar-04	83	91
Apr-04	73	47
Oct-04	58	81
Nov-04	54	88
Dec-04	44	31
Feb-05	49	84
Mar-05	58	56
Apr-05	54	51

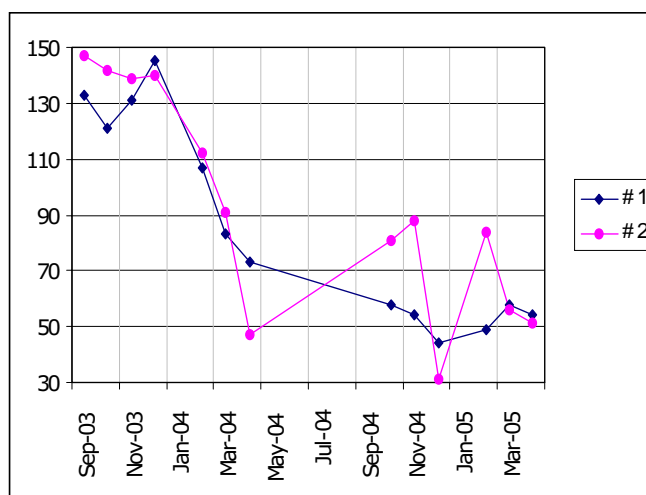

Monthly average stack opacity has got reduced drastically from :

- 145 mg/Nm<sup>3</sup> in Dec-2003 to 54 mg/Nm<sup>3</sup> in Apr-2005 in Unit #1
- 140 mg/Nm<sup>3</sup> in Dec-2003 to 51 mg/Nm<sup>3</sup> in Apr-2005 in Unit #2

ESP precipitator current and voltage have improved and spark rate has got reduced. Better control of SPM is now possible with lesser ammonia dosing

**Financial analysis**

Cost of Ammonia Gas – Rs. 2100/- per cylinder. Around 60 to 70 cylinders are required for both the units per month.

#### 4.4.2. Case Study

### INITIATIVES TOWARDS ACHIEVING THE STATUS OF ZERO EFFLUENT DISCHARGE IN A THERMAL POWER STATION

#### Background

In a thermal power plant the waste water generally comes from Boiler and turbine area. The waste water generally contains fly ash particles. These plant drains ultimately discharged to near by water body. Draining of waste water to the water body leads to water pollution.

Since water is a scarce commodity, there is a need to minimise the fresh water consumption in the plant. One of the ways of minimising the fresh water consumption is recycling / reuse of water in the plant itself.

In a thermal power station, recycled water could be utilised for the following purposes.

- Formation of ash slurry for disposal
- Dust suppression in coal stacking yard
- Development of lawns and gardens
- Fire quenching in coal stacking yard

This recycling of water and reuse of the same for the internal consumption will result significant reduction in fresh water intake and ultimately result in achieving the status of “zero effluent discharge” plant.

#### Present status

The thermal power station has 2 x 120 MW and 3 x 210 units. The thermal power station was constructed in three different stages. Since the plant was constructed in stages, the drains were also constructed accordingly. Ultimately these drains were connected to near by river at different locations. The total quantity of waste water discharged was about 1000 m<sup>3</sup>/day.



**Project Implemented**

The waste water contains ash particles. It is essential to remove them before utilisation. For removing the impurities, decantation sumps were constructed close to the drain.

The connections between the drain and decantation sump are made in such a way that at one end the waste water enters the decantation sump and the impurities settles down in the sump.

At the end of the sump, clear water sump is provided and pumps are installed to pump only the clear water.

The water from the clear water sump is utilised for the following purposes:

1. formation of ash slurry
2. dust suppression in coal stacking yard
3. fire quenching in coal stacking yard
4. development of lawns and gardens

The line diagram for the installed system is given below.

The recurring expenditure involved is for cleaning of sumps which is carried out periodically as per requirement, which is normally 3 months.

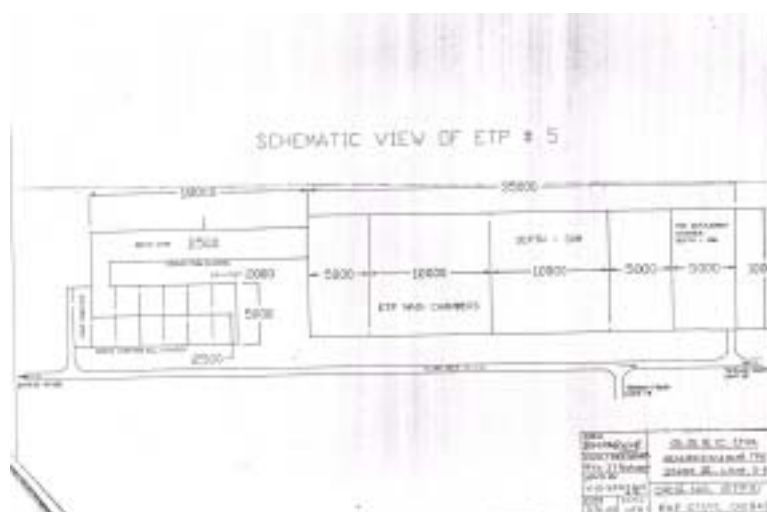

**Benefits**

After installing the waste water collection system, about 1000 m<sup>3</sup> of waste water is utilised per day.

With the existing scheme, “zero effluent discharge status” was achieved.

**Financial analysis**

With the present water cost of Rs 4.50 / m<sup>3</sup>, total cost saving of about **Rs 16.2 Lakhs** was achieved. Total expenditure incurred for the sumps and the pumping system was about **Rs 30.00 Lakhs**. The simple payback period is **23 Months**.

**4.4.3. Case Study****MINIMIZING SO<sub>2</sub> EMISSION AT IN A 500 MW THERMAL POWER STATION****Background**

Trombay Thermal Power Station belonging to Tata Power Co. has a major share in meeting the power requirements of Mumbai, the commercial capital of the country. It started its journey with installation of three units of 62.5 MW and one unit of 150 MW during the period 1956 - 1965.

With increase in demand, generation capacity is augmented to 1300 MW presently. The station has multi fuel (Oil, coal, gas) fired Units (1\*150 + 2\* 500 MW) & one combined cycle Unit (180 MW). In its journey since 1956, performance improvement from 26.0 % design thermal efficiency (for old 62.5 MW Units which are decommissioned) to a higher range of 36 - 45 % is achieved by 1994. While providing a reliable power and service to our consumers, TPC is committed to Environmental protection & enrichment. This paper gives details of environment friendly practice for minimizing SO<sub>2</sub> emission which is unique in India.

**Previous Status**

Fuel quality and fuel mix is mainly governed by SO<sub>2</sub> emission norms laid by Maharashtra Pollution Control Board (MPCB) for the Thermal Power station.

## BEST PRACTICES IN INDIAN POWER PLANTS

As Capacity of plant increased during the period 1984 - 1994 from 330 MW to 1330 MW, pollution limits were made even more stringent for the plant.

SO<sub>2</sub> emission was decreased from 62 Tons/day to 24 MT /day in the statutory consent. It represents second most stringent limit of SO<sub>2</sub> for a plant of similar capacity in the world as shown in Graphic 1.1. But lower the SO<sub>2</sub>, higher is the fuel cost of generation. Therefore meeting higher demand of electricity (plant output) while remaining within SO<sub>2</sub> norms and fuel cost of generation provided a challenging opportunity. This paper describes the practice followed for meeting the combined requirement by a flexible fuel mix and flue gas desulphurization process.

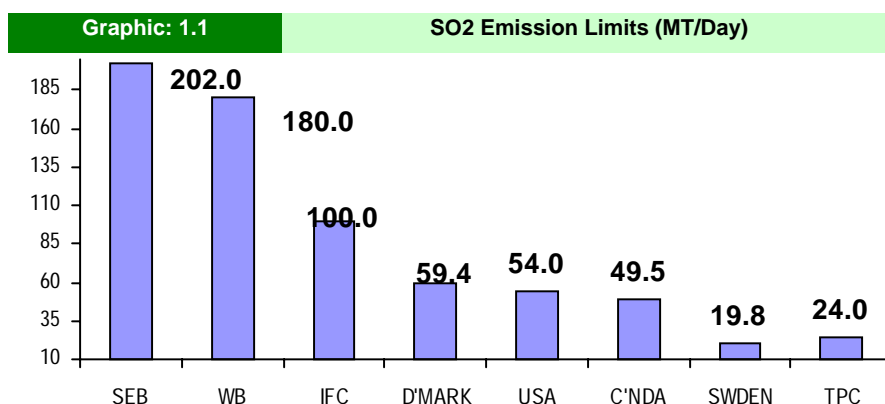

### Implementation challenges

- a) Optimization of Fuel Mix

#### **OIL: (LSHS / LSWR)**

Location of this plant is in the neighborhood of BPCL and HPCL refineries. The plant is using the residual oil from these refineries received through direct pipeline.

Till 1983, Indian coal was also being used for power generation. TPC was the also first user of Bombay High gas in 1976 when ONGC piped it to Trombay terminal.

### ***Manual on best practices in Indian Thermal Power Generating Units***

---

However after the new stringent norms of SO<sub>2</sub> since 1984, plant started using Low sulphur Heavy Stock (LSHS). Oil and gas was the major fuel during the period 1983-1999.

With increasing power demand and dwindling clean fuel gas supplies, BPCL / HPCL supplies were supplemented with very low sulphur (< 0.3 %) oil mainly from IOCL Koyali refinery in Gujarat brought through rakes.

As power demand grew further, sulphur in oil had to be reduced reduce further and oil supplies were augmented through imported Low Sulphur Waxy Residue (LSWR) with 0.15 % sulphur to limit SO<sub>2</sub> emissions. A pipeline infrastructure was made from neighboring jetty to import LSWR from 1996.

After 2000, availability of natural gas to Trombay plant further reduced drastically as shown in Fig-2, making it more challenging to limit SO<sub>2</sub> emissions. As fuel oil prices started soaring, the dependence on oil had to be cut down. Switching over to more environments friendly and also relatively cheaper coal was the only alternative.

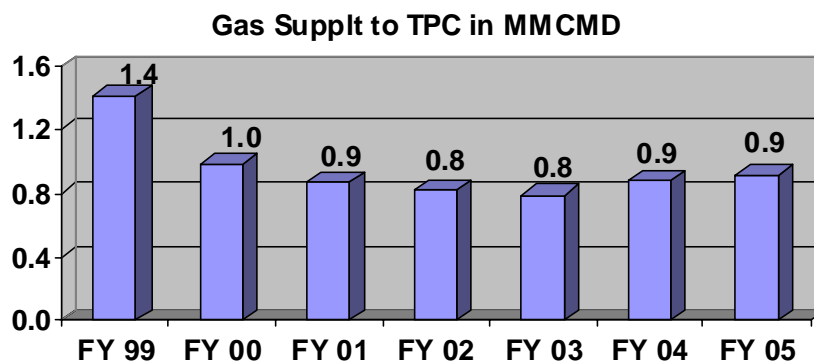

#### **Coal:**

Coal was initially fired in 150 MW Unit 4 till 1982. With commissioning of Unit 5 in 1984, coal firing was restricted to 1470 MT/day with Indian coal (High sulphur - 0.5% & high ash - 40%). With phenomenal increase in oil prices after 2000, there was a need for increased coal firing to remain cost competitive. However due to limited

space for ash disposal at coastal station of Trombay and strict SO<sub>2</sub> norms, it was not possible to use Indian coal with high ash / sulphur content. Also transportation distance from nearest coal mines was more than 800 KM. Hence option of firing imported coal was explored. Use of imported coal (Chinese coal) with 0.3 % sulphur and 10 % ash was started in 1998.

With increasing demand for electricity and SO<sub>2</sub> limit remaining same (24 MT/day), use of Imported Indonesian Coal with lowest sulphur 0.1 % and ash (1 to 2 %) ash was tried for the first time in September 2001. After successful trials of Indonesian Enviro friendly coal, usage of such coal is increased to 100 % on coal fired 500 MW unit 5 since July 2004.

### **Flue Gas De-sulphurisation Plant**

As mentioned above, use of low sulphur fuels was implemented to cut down SO<sub>2</sub> generated at the station. However usage of low sulphur fuels alone was not sufficient to limit SO<sub>2</sub> emissions. Anticipating stricter SO<sub>2</sub> norms Trombay plant was simultaneously upgraded with new environmental technology while designing the 1st 500 MW unit in the country.

First Flue Gas De-Sulphurisation stream (FGD) was commissioned in 1986 at Trombay and other stream was added in 1994 on unit 5. Two third (66.0%) of total flue gases are treated for SO<sub>2</sub> removal here. It is the only FGD plant presently working in India. The scrubber efficiency (SO<sub>2</sub> removal efficiency) is observed at 90 % against the manufacturer's guarantee of 85 % removal.

### **FGD Process**

Being a coastal station, Trombay FGD is designed to work on sea water process, using untreated sea-water to scrub the flue gas, exploiting the water's natural alkalinity to neutralize the SO<sub>2</sub>. The chemistry of the process involves bicarbonate from the sea water reacting with the SO<sub>2</sub> and oxygen (from the aeration process) to form Sulphate. Fig 3 shows schematic of FGD process.

The sea water is obtained from the steam turbine condenser outlet as the water is warmest at this point. Part of this water is pumped into the top of the absorber tower.

As the water falls down the tower, it passes through the packing, and comes into intimate contact with the rising flue gas.  $\text{SO}_2$  is thus dissolved in the water and removed from the flue gas. The effluent is collected in the absorber sump. It flows then under gravity into the external mixing basin and aeration lagoon. Here it is diluted with the further quantities of sea water from the condenser outlet, and aerated with air blowers to reduce the chemical oxygen demand, and raise its pH to neutral range. The treated effluent with adequate dissolved oxygen is then discharged back to the sea.

At the top of the absorber, the gas passes through a single stage demister to remove suspended water droplets.

After leaving the absorber, the gas is passed through the re-heater again, to raise its temperature before going to the stack.

Fig 3

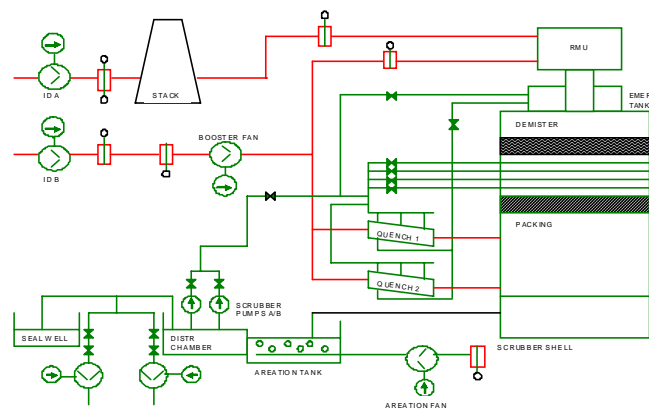

The main advantage in this FGD process is that it requires no solid absorbent as a reagent, unlike nearly all other FGD processes. The plant design is simple resulting in relatively low capital and operating costs as compared to other FGD technologies. Most importantly there is no purchase cost for the absorbent, no disposal cost and no requirement for traffic movements and the associated handling infrastructure. However there is additional auxiliary consumption for fans, pumps, air pre heater. There is no secondary pollution as Sulphate formed is a part of sea water.

**FGD Features**

- ❖ Investment for 1 unit : 47 CRORES (In 1986)
- ❖ Removal Efficiency: > 90 %
- ❖ Use of Sea Water: 4000 M3 / Hr
- ❖ No solid waste Generation
- ❖ No Secondary pollution

**FGD Plant at TPC Fig – 4****Challenges in FGD Operation**

The three areas have been corrosion, erosion and fouling as under:

- ❖ Due to the use of sea water which is corrosive, it requires lining of equipment (e.g. rubber lining, epoxy, FRP coating etc.), and moving up into alloys with High in Nickel and chrome. This extends the useful life, but at a substantially higher costs.
- ❖ FGD causes a major impact on total plant cost and needs to take care of implosion protection.
- ❖ Auxiliary Consumption: FGD plant adds to the auxiliary consumption of the plant to the tune of 2.5 MW. However auxiliary consumption was cut down

almost by half (in the second unit) by placing booster fan in cold gas path (after scrubber instead of before scrubber in first unit)

- ❖ Scrubber packing material is inflammable and needs special precautions against fires. (In stand by condition / Outage of FGD minimum flow of water is maintained to keep it wet)

### **SO<sub>2</sub> Optimization Programme**

It is necessary that SO<sub>2</sub> emissions should not be looked in isolation as it is linked with fuel cost of generation. Lower sulphur in fuel is required to limit SO<sub>2</sub> emission.

However lower the sulphur in fuel, higher is its cost. Hence optimum balance of SO<sub>2</sub> and fuel cost has to be reached for a given station generation on daily basis. Also higher the electrical generation, higher is the fuel consumption and so its impact on SO<sub>2</sub> has to be considered additionally.

Therefore, a fuel mix optimization linear program was developed in-house using Microsoft Excel to optimize three variables: Generation, Sulphur and Cost.

Using this program, daily fuel requirement is planned to restrict the total SO<sub>2</sub> emissions below 24 TPD. Daily generation is forecast from past data, and superimposing events like seasonal climatic changes, holidays or Sundays, telecast of major events etc. by load Despatch center and used as one input.

Other inputs for this program are quantity and quality of fuels i.e. sulphur in oil, coal and quantity of oil/coal/gas to be used. Oil tanks are segregated on the basis of sulphur content. Sulphur content in each oil tank is monitored on daily basis.

The program advises the right blend of oil from various tanks to be used on daily basis optimally.

### **Benefits:**

Based on (i) the varying Sulphur content and (ii) the prices of the available fuel stocks in the tank farm, it enables Trombay to forecast on a daily basis, the optimum fuel mix for the next 24 hours.



## BEST PRACTICES IN INDIAN POWER PLANTS

This program has enabled Trombay to determine the daily consumption of an optimum combination of relatively cheaper grades of LSHS having higher Sulphur content ( $> 0.5\%$ ) with the more expensive low Sulphur LSHS ( $< 0.3\%$ ). This optimization helps to generate desired power daily at the lowest cost and yet conform to the 24 TPD emission limit.

Over the year the installed capacity has increased from 330 MWH to 1330 MWH with decrease in SO<sub>2</sub> emissions form 62 to 24 TPD as shown in fig – 5.

Fig : 5

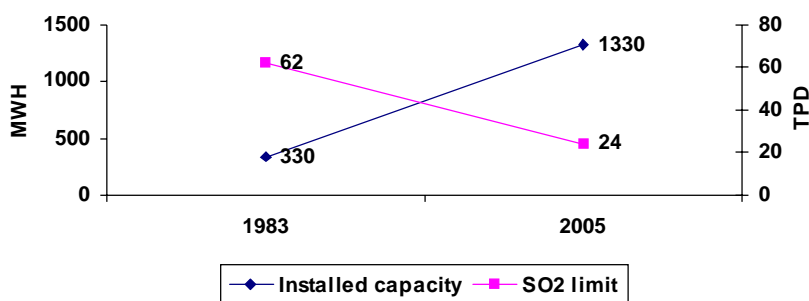

Optimizing use of FGD along with use of low sulphur low ash coal and low sulphur oil, Trombay Plant has benchmarked SO<sub>2</sub> emission from Oil & coal fired units as under:

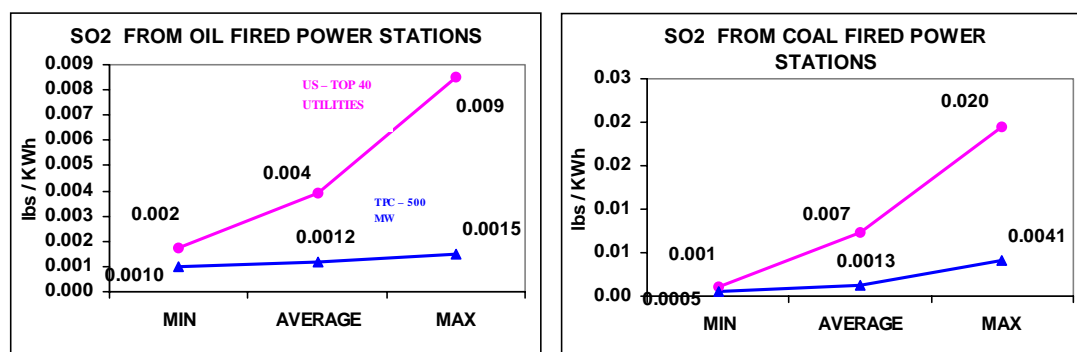

An optimum balance of SO<sub>2</sub> emission & fuel cost of generation is thus achieved for the benefit of the stakeholders.



## **4.5. MISCELLANEOUS PROJECTS**



#### **4.5.1. Case study**

##### **DEPARTMENTAL WEBSITE – AN INNOVATIVE TOOL FOR DATA AND KNOWLEDGE MANAGEMENT**

###### **Background**

During power plant operation enormous amount of data is generated. The management of this data becomes very difficult and tedious over the period of time.

Similarly, during the operation of power station people gain experience and knowledge about the plant specific systems and their problems. This knowledge needs to be passed on to next generation of employees.

The department website is an effective tool to manage the data and pass on the knowledge accrued over a period of time to the next generation.

###### **Present Status**

This data generated in a power plant on day to day basis may be related to process parameters, events, and trends, log sheets, defects observed, various performance tests, inspection and checking, etc.

The departments like, maintenance, stores & purchase, finance & HR also generate similar data. This data is converted into different MIS for easy understanding.

Over a period of time the management of data becomes difficult. It requires huge space for storage. It needs extra resources for safe storage. Even after proper storage, retrieval of data becomes difficult.

There is a likelihood of loss of data for multiple users. Human intervention is required to make the data available.

Over the years of operation of power plant, operation and maintenance people gain experience during different kinds of emergencies and other such events like unit trippings, specific problems of different systems; gain experience during overhauls, etc. The knowledge dissemination is very limited.

All these problems could be eliminated by integrating the data generated by various departments using ERP package. The use of ERP generally integrates the storage of data and information.

To retrieve specific data / reports using ERP, knowledge of software is required. The ERP has a very few customised formats of reports.

### **Project implemented**

For data and knowledge management there is a need for a system which will provide error free data with no reprinting and recompilation work in a required format. Similarly it should also facilitate smooth and easy transfer of knowledge. Accordingly customised websites were developed for individual departments to get offhand information for day-to-day use. Sufficient Attention was paid to the content, the organization's information needs, and how people will be able to use the intranet.

The intranet designing needs an understanding of strategic planning processes, communication models, the organization's strategic plan and business objectives, the company's culture and work environment etc.

The website was developed with the help of in-house expertise, skill and knowledge of employees of organization who have operational and process knowledge.

### **Website & Contents**

Web is developed with menu and sub menus format. Main menu and Sub menu is developed with the help of JAVA SCRIPT programming technique and submenu are attached to main menu.

Advantage of Java Script is that it makes loading and display of called pages from main server at desired terminal very fast. The related data report pictures are attached with sub menu with HTML SCRIPT. All reports which are generated at first hand in word / excel formats are converted to html document and then attached to respective submenu.

The front page / home page of the operation department site consists of following main menus.

---

**BEST PRACTICES IN INDIAN POWER PLANTS**

---

- ❖ **Plant performance:** This consists of various plant performance reports generated at specific interval like daily, monthly, etc.
- ❖ **Documentation:** ISO documents, quality improvement plans, deviation approvals, logbook, formats, training material, etc. form the documentation section.
- ❖ **Study report:** This section consists of all-important studies, which are carried out at DTPS for performance, reliability and profit improvement.
- ❖ **Analysis:** This consists of sub menus like event analysis, tripping analysis, efficiency test analysis, start up and down time analysis, Auxiliary performance, etc.
- ❖ **Software Package:** consist of in house develop packages like Daily Plant report, heat rate optimizer, fuel cost optimization coal blending economics.
- ❖ **Presentations:** This section contains various presentations prepared by employees of operation department on subjects like reliability; profit improvement, knowledge improvement and operation refresher presentations.
- ❖ **Commissioning:** This includes details about support extended to EPC group for commissioning of various power stations.

Similarly websites for other departments have been developed and then interlinked for easy accessibility.

It was ensured that the data available in the site is accurate and updated regularly. Only few employees have access to edit the data on the site. To avoid the loss of data, daily / monthly schedule of data back up has been adopted. The data back up is taken on another server and on a CD on monthly basis.

**TYPICAL TREE DIAGRAM OF A DEPARTMENT WEBSITE**

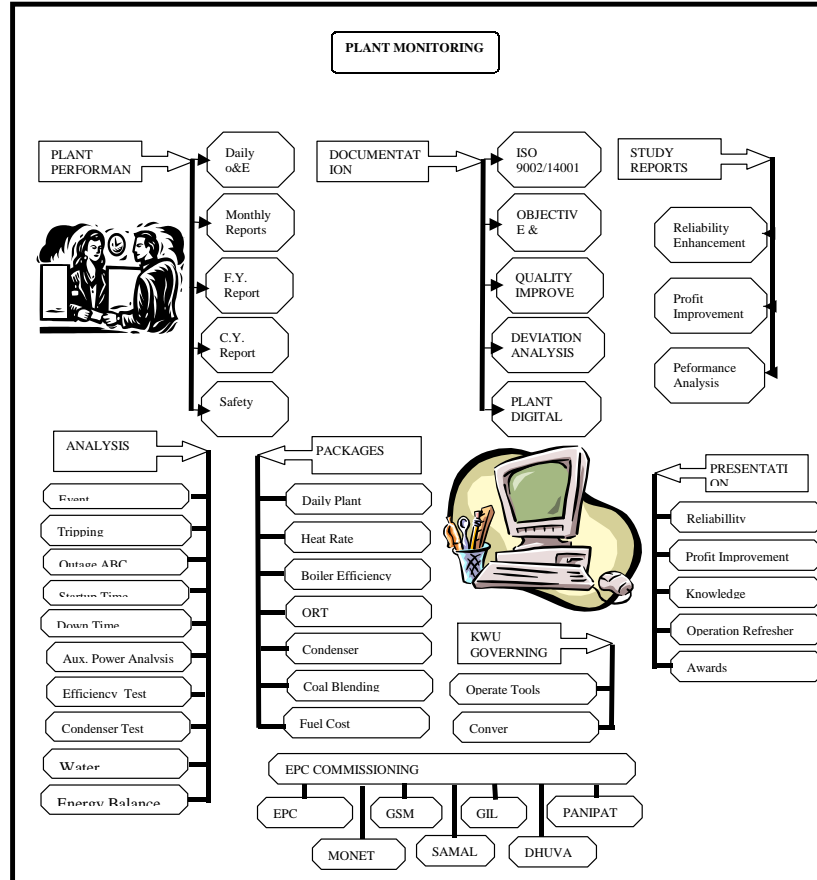

**Benefits**

- ❖ Availability precise data at any instant for study and reference. It is very easy to see and retrieve compared to past practice.
- ❖ Multiple users are able to access same data from different locations at a same time.
- ❖ Loss of data is avoided, as the data is stored in soft form with password protection.
- ❖ Cost reduction by avoiding unnecessary printing and copying in hard copy of reports.
- ❖ Knowledge sharing by availability of reports and analysis to different people of different departments.



#### 4.5.2. Case study

### **RAINWATER HARVESTING IN THERMAL POWER STATION**

#### **Background**

Water is a primary requirement for the people, agriculture and for the industry. Water is a valuable resource, which is depleting fast. Depletion of water resource is a result of indiscriminate exploitation and wastages by the industries.

Thermal power plants are one of the major water consumers. This also discharge of significant quantity of waste water. Thermal power plants has larger area for rainwater collection. Rain water harvesting is an economical and sustainable method of conserving water in thermal power stations.

#### **Previous status**

The thermal power station is situated in northern part of Gujarat state where the ground water levels were showing depleting trend. Ground water is one of the major source of water supply for the thermal power station.

The state was undergoing severe drought condition and there was acute shortage of water. The thermal power station was only depending upon ground water for its water requirement.

#### **Project implemented**

Various locations, where there was considerable flow / accumulation of rain water were identified in colony as well as in power plant. Initially single Dug cum bore wells were constructed as per the drawings.

The specifications of dug cum bore wells are as under:

- ❖ Depth - 5 m Below ground level
- ❖ Diameter - 2 m
- ❖ Depth of bore - 15/25 metres depending upon the location
- ❖ Diameter of bore - 250 mm
- ❖ Diameter of pipe - 150 mm PVC pipe with slots

***Manual on best practices in Indian Thermal Power Generating Units***

---

The annular space between the bore – hole and PVC pipe is filled with 3 mm to 6 mm size gravel. The well is provided with filter of 800 mm thick comprising of 500 mm thick gravel and 300 mm layer of coarse sand.

Netlon screen is provided between gravel layer and sand layer to facilitate periodic cleaning of sand layer, which is required.

Further to above, 500 mm wide and 1200 mm deep external filter well is also provided on outer side of the well at ground level with filter material as under.

- ❖ 300 mm thick pebbles
- ❖ 300 mm thick gravels
- ❖ 300 mm thick coarse sand with Netlon screen at bottom to facilitate screening.

The external filter is covered with pre cast RCC covers with holes to facilitate entry of water in the filter. From this filter, the water is taken to well by 200 mm diameter PVC pipes water spouts. These water spouts are placed at 30 degree radially along the periphery of external filter.

Initially dug cum bore wells were constructed without external filter. There after modification was made with provision of external filter also, so that minimum quantum of foreign materials enters the main well, there by making cleaning more easier. Further, Netlon screen is also wrapped around PVC slotted bore well pipes, so that foreign materials do not enter the bore well.

Later it was observed that there were areas where the quantity of rain water was excessive and single dug cum bore well was inadequate for those areas. The design was modified and twin dug cum bore wells were proposed. The construction features are similar to single dug cum bore well. The following modifications were taken up.

- ❖ Depth - 4 m
- ❖ Diameter of bore well - 3.040 m
- ❖ No of bores - 2 Nos
- ❖ One bore with 34 m and the other with 24 m below ground level.
- ❖ Bore diameter - 250 mm

The schematic diagram of single dug cum bore well and twin dug cum bore wells are shown below.

**Single Dug cum bore well**

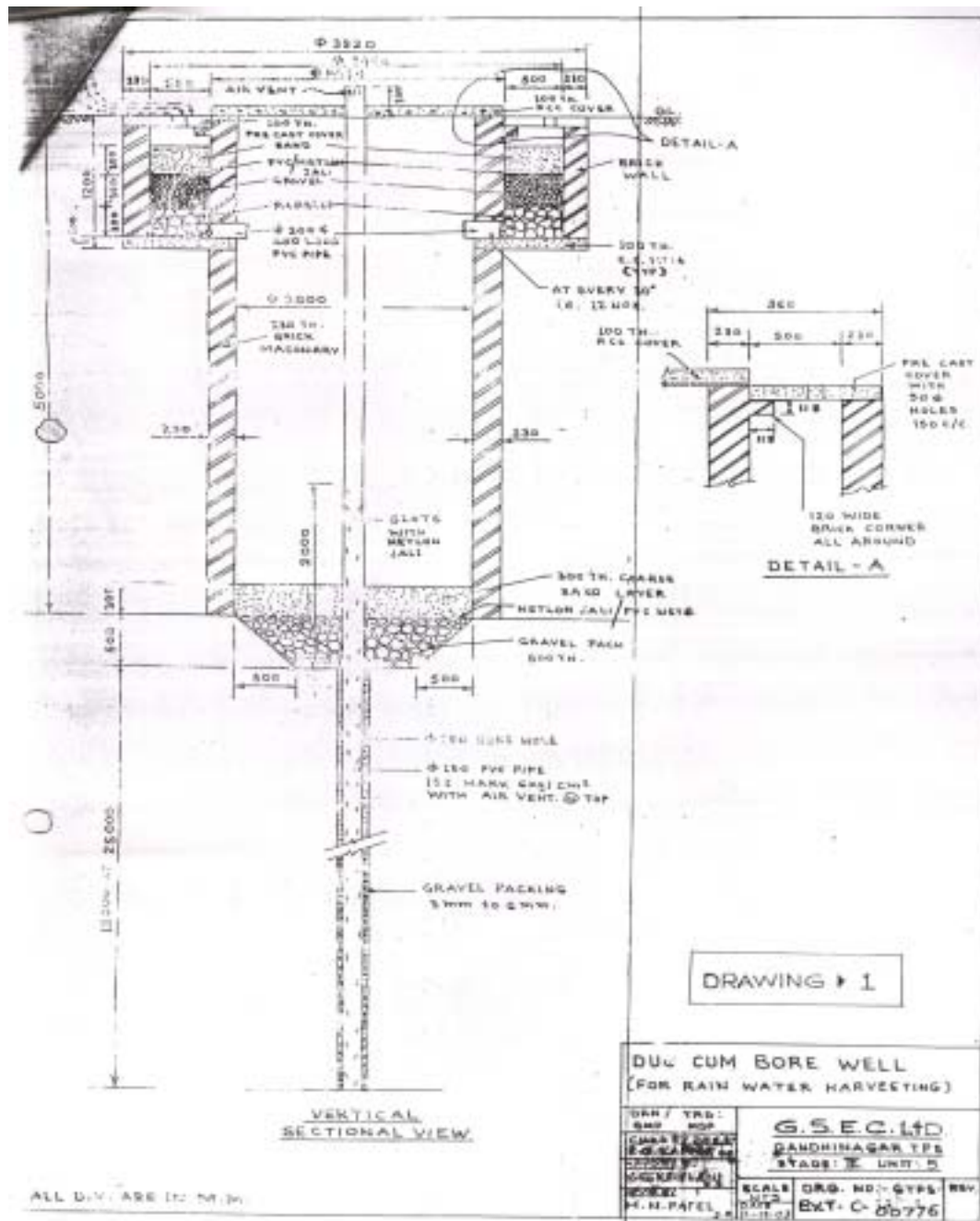

**TWIN DUG CUM BORE WELL**

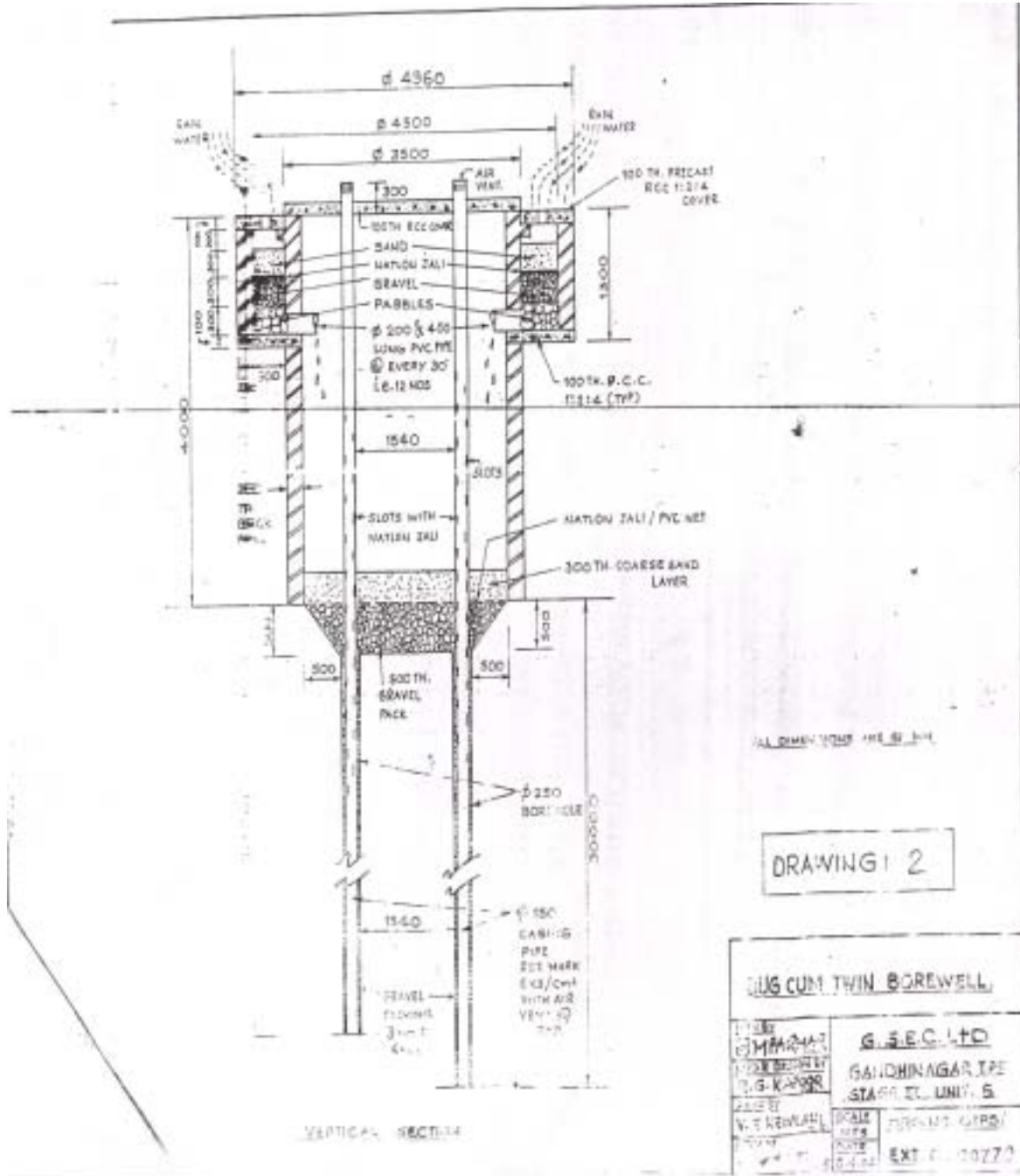

**Benefits**

Presently the financial benefits are not available. However the water table is expected to raise which will increase the availability of water for the plant's uninterrupted operation.

**Financials**

The expenditure involved for single Bore well is Rs 57,700/- per bore well and that for twin dug cum bore wells is Rs 1,07,450/- per bore well.

**4.5.3. Case study****MEETING CUSTOMER EXPECTATIONS IN THERMAL POWER PLANT****Background**

Sustenance of any organization is determined by how well the needs of its customers are met. Electricity is no exception. With the introduction of Electricity Act 2003, the responsibility of providing reliable power at affordable tariff to customers has gone up many folds by the power utilities. In a Metro like Mumbai uninterrupted power is something which is taken for granted and hence this need has to be met by power plant utility on a continuous basis.

There are several customer segments in power industry. Each customer segment has its own requirements – industrial customers require uninterrupted supply with stable voltage and frequency within stipulated limits, commercial consumers require uninterrupted power at reasonable cost, domestic consumers require power at low cost with payment convenience. Besides this there could be some requirements which are specific for each customer.

In order to understand how well customer need is met there has to be a regular feedback from the customer. Hence Customer satisfaction needs to be measured on the basis of various attributes as applicable to a given segment to determine the present levels of power supply and service. Based on these, the feedback received are to be converted to action plans & plans need to be implemented where product and service

## ***Manual on best practices in Indian Thermal Power Generating Units***

---

standards need further improvement. Not only customer satisfaction, but customer dissatisfaction also needs to be captured and measured, if one wants to gain customer confidence. It is a continuous process of improvement.

Similarly customer complaints also need to be monitored and addressed effectively. It serves the purpose of improving service standards where it lacks customer's expectation and also to comply with the Service Standards as prescribed by the Regulatory Authority as well as utility's own internal standards.

Tata Power Company ( TPC ) supplies power to wide range of customers namely – Distributing Licensees, HT direct consumers like refineries, railways etc, , State Electricity Boards, direct LT customers including Residential consumers etc in its Licensed Area of Supply.

This note covers how these customer's requirements are addressed by TPC while striving to achieve best customer service.

### **Previous Status**

Originally TPC used “Complaint management process” to ensure prompt and effective resolution of customer complaints. Following methodology was used for receiving complaints

- Call centre available round the clock,
- Respective Centralized Control Room nodes,
- Divisional control rooms
- Fault duty engineers directly due to long-term relationship
- Written complaints

Complaints were immediately recorded and forwarded to concerned authorities for suitable action. Majority of the Technical complaints are about power interruptions

### **Project Implemented**

Process of meeting customer expectations was strengthened in last 3 years in following areas

- Customer requirements process

- Complaint management process
- Customer satisfaction survey

Following improvements have been executed :

- **Better understanding of customer requirements :**

Process of understanding customer requirements is strengthened through consumer meets, consumer forums, focus group discussions & feedback on transactions & customer requirement survey (CRS)etc

- **Enhanced focus on complaint analysis**

Following flow chart indicates process for customer complaint management and analysis. Regular Customer Co-ordination meets are held where complaint data collected by call centers, control rooms, service personnel is collated. Necessary root cause analysis is done and input is given to Engineering Department for design changes, Electrical Quality Assurance Department to check for specific points, & Human Resource department for necessary training. Data for both technical and commercial complaints is aggregated. It has been codified to track different types of complaints segment wise. Compilation of customer complaints is done and monthly MIS sent. Consolidated MIS of all customer complaints is forwarded to all in the Customer Response Chain. Analysis of customer complaints is carried out at divisional level and improvements achieved are discussed and shared in the monthly customer co-ordination meetings. Daily complaints are conveyed to the divisions through MIS.

- **Customer Complaint management**

Focus groups for licensees and public utilities / essential segments meet the respective customers regularly, in order to understand their specific requirements and concerns. Customer meets are held for licensees, HT and LT (Industrial / commercial) and residential customers once every year. Senior leadership team directly interacts with customers and apprises them on TPC's new ventures, services and plans. It also gives an opportunity to the customers to directly interact with them and raise concerns.

**Manual on best practices in Indian Thermal Power Generating Units**

The improvements made based on suggestions received during consumer meet / visits / mailer are aggregated, shared across the company and communicated to the customers.

Officials regularly interact with the senior officers of SEBs, which helps in maintaining relationships and identifying future business opportunities.

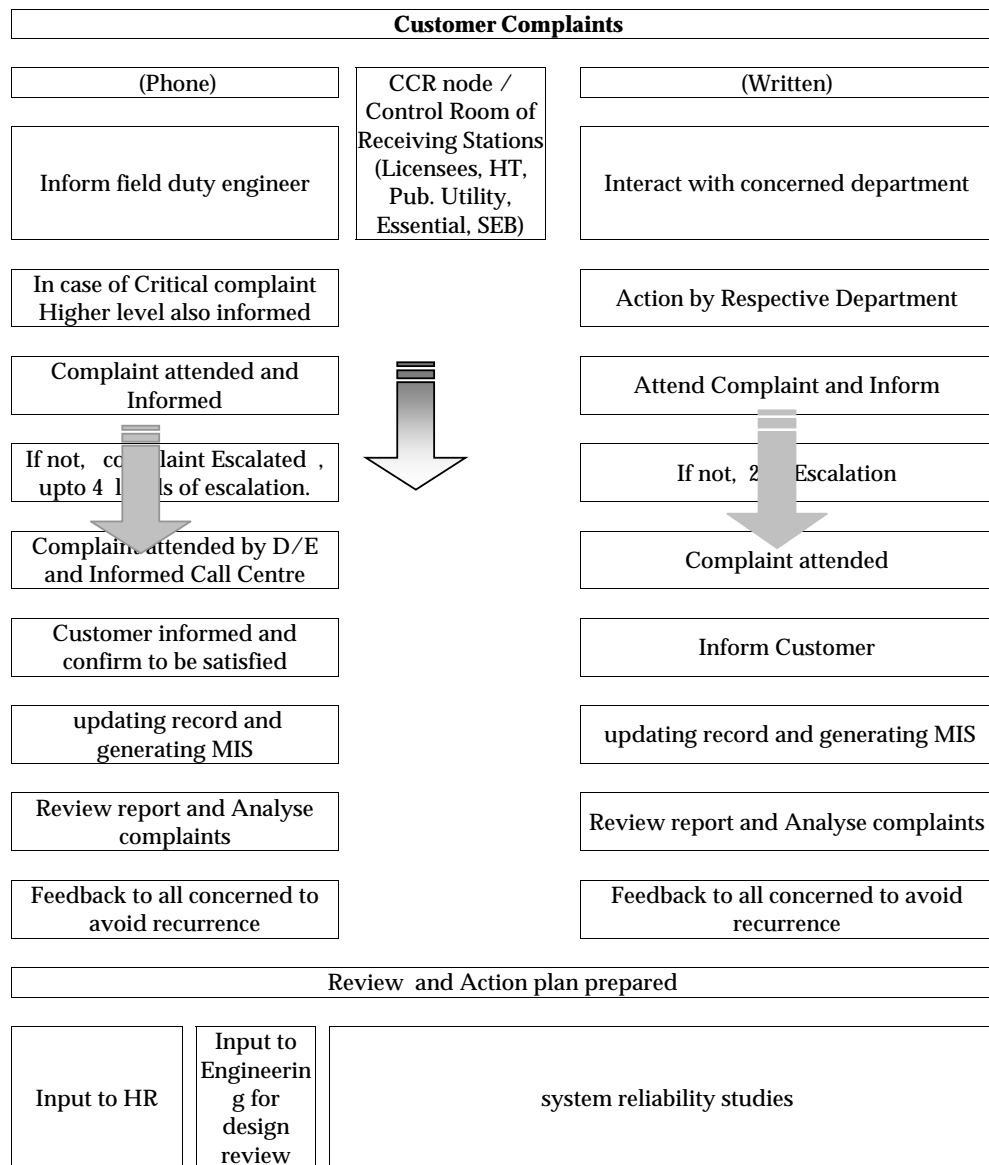



- **Improved communication**

List of Frequently Asked Questions (FAQ's) is provided to the Call Centre staff which enables them to directly answer routine customer queries. A list of contact persons is available with the Call Centre, so as to reduce the total complaint resolution time.

- **Improvement in Service standards**

They are set for following in terms of time required to serve the customers:

- i) Provision of supply
- ii) Release of power supply
- iii) Restoration of power supply

Service standards are set for TPC staff, service agency and Call Centre. These are included in goals set for such officers.

- **Customer satisfaction**

Customer satisfaction & dissatisfaction surveys are carried out annually with the help of external agency who are expert in such research activities. The survey covers all customer segments, customers of other utilities & opinion leaders. The process consists of customer feedback through survey/interviews based on criteria of importance ,analysis of data, & determination of rating with reference to customer requirement

Customer satisfaction index (CSI)is computed based on volume of business from various segments (weighted average index instead of simple average).It has resulted in identifying performance level in high impact segments.

For getting further insight ,customer dissatisfaction index( CDSI) is also being monitored & tracked separately. TPC has managed to control dissatisfaction through communication & by providing adequate services within the framework of the regulation.

### ***Manual on best practices in Indian Thermal Power Generating Units***

---

CSI & CDSI ultimately leads to preparation of an action plan based on the findings & deploying it .Over the years, business needs have been changing .Improved accessibility, raising service standards to meet customer expectations, ease of paying bills have been some areas where improvements have been made.

- **Value for money**

One of the key factors in purchasing decision of the customers is the value for money which includes attributes of cost & service. As a result of increase in tariff due to increased fuel price & various regulatory constraints, it has a negative effect but still TPC performance is better than others in the area.

#### **Improvements and Benefits**

<b>Year</b>	<b>Improvements</b>
2002-03	Customer satisfaction survey to capture changing customer needs.
	Customer meets to cover all segments to build relationship
	Customer requirement survey initiated for deeper understanding of key customer needs.
2003-04	Customer Requirement survey process refined to capture importance factors.
	Customer information portal introduced as a part of TPC web page to serve as two way sharing & addressing concerns /queries.
	Customer complaint management process strengthened to improve service standards.
2004-05	Increased no. of customers in CSS.
	In line with regulatory requirement TPC has set up Consumer Grievance Redressal Forum. Also Government of Maharashtra has appointed an Ombudsman as per MERC guidelines, to enable customers to escalate unresolved complaints.

Key indices like CAIFI, SAIFI, CAIDI, SAIDI, reliability index and billing integrity index have been developed and are monitored regularly.

They are defined as follows

- i) **Reliability index** : It is the total duration of interruption in minutes per customer per year & includes planned & forced interruptions. Fig 1 shows reliability index for TPC in last 3 years .

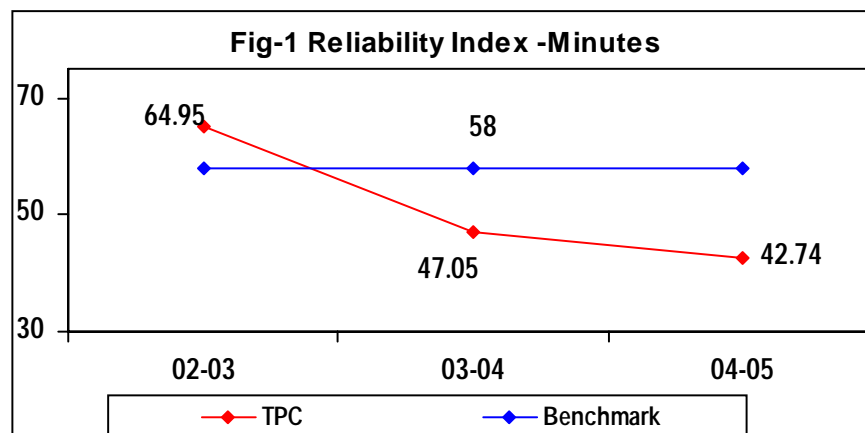

TPC has taken specific initiatives like network improvement (reconductoring, line fault locators, automation of critical network to reduce restoration time after fault.) & stringent monitoring of network, root cause analysis, fuse coordination, review of transformer protection etc.

- ii) TPC is also monitoring

**CAIDI** : Average **interruption duration in minutes** for customers interrupted during year.

**SAIDI** : Average interruption duration in minutes for customers served during the year.

**CAIFI** : It is the average **number of interruption** per customer interrupted per year.

**SAIFI** :It is the average number of interruptions per customer served per year.

Fig 2 shows improving trend of CAIFI/SAIFI .This is achieved by network modifications, bird fault preventive measures, and conversion of O/H lines to

U/G cables. Thermo-vision Scanning of heavily loaded network is carried out to detect incipient faults and avoid forced interruptions

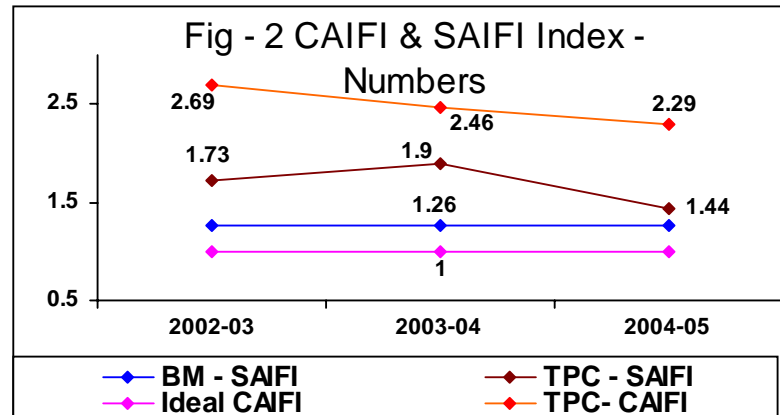

TPC has been monitoring these indices for last 3 years .Now MERC has asked all power companies to monitor above indices.

- iii) **Billing integrity index** : It is the number of complaints received over every 100 customers billed. Surveys & customer interactions have highlighted billing & bill payment as an area for improvement. Fig 3 shows improving trend of billing integrity index.

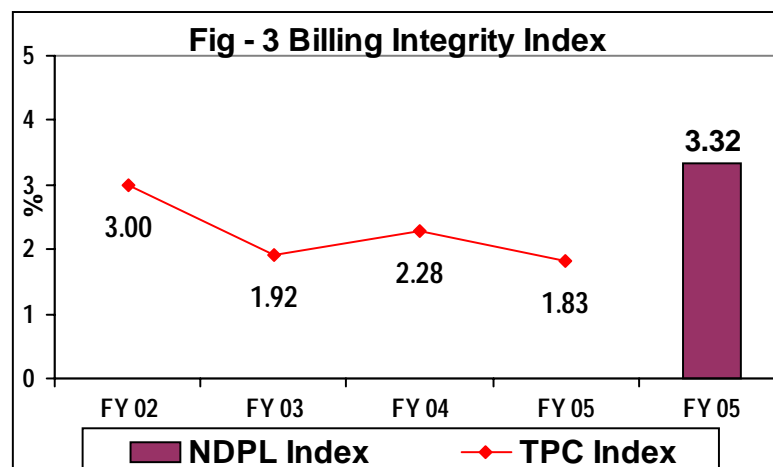

- iv) **Billing complaint response index** : it is % complaints resolved within 24 hrs .Fig 4 shows the trend for last 3 years.

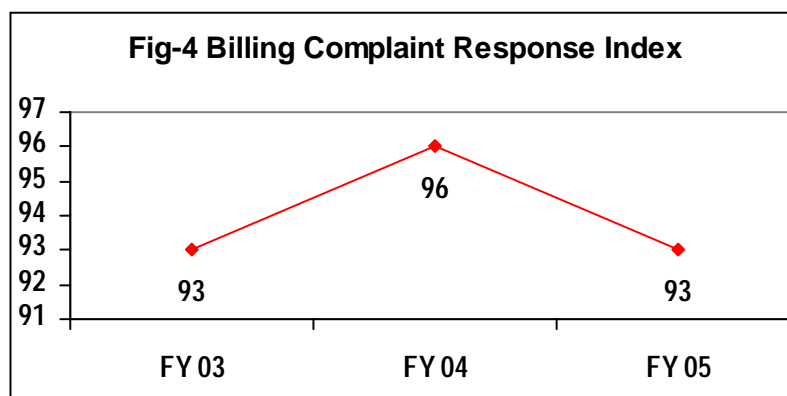

In FY 05, this index has reduced marginally due to customer perception of higher billing .Customers wanted their meters to be tested in their presence. However in most of the cases the meters were found to be registering accurately.

- v) **Service complaints** : Table shows service complaints due to voltage Hi/Lo & voltage fluctuation .It is being addressed by commissioning more distribution substations( with regulated 11 KV distribution ) & tap changing of transformers. Voltage fluctuations are generally a result of grid level tripping however some voltage fluctuations are due to local causes at LT distribution level/consumer end. These are addressed by add on services.

<b>Service Complaints</b>			
<b>Complaints / 100 Customers</b>	<b>2002-03</b>	<b>2003-04</b>	<b>2004-05</b>
Voltage High / low	0.25	0.43	0.53
Voltage fluctuation	1.00	0.91	1.09

- vi) **Customer satisfaction** : Fig 5 shows improvement in customer satisfaction index. TPC strives to maintain its leadership position in this regard.

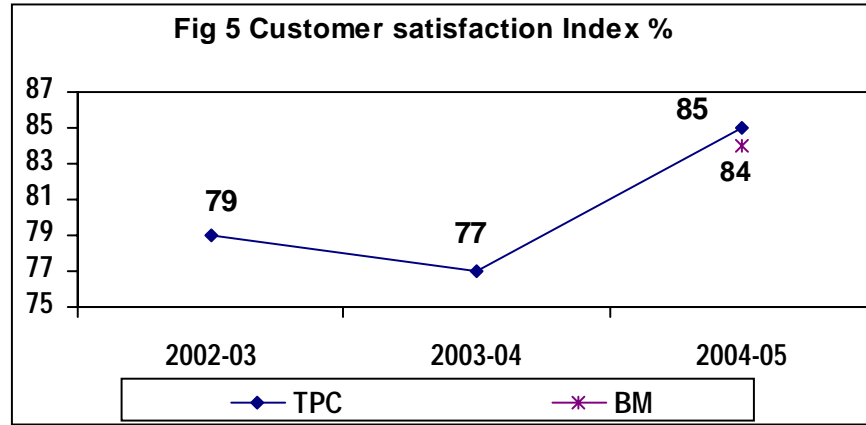

Thus it can be seen that customers are the most important link in the business & it is imperative to strive hard to meet their expectations by monitoring and taking appropriate actions in correct direction for continuous improvement in service standards. Benchmarking(BM) can be used as a tool to improve this process.

## **CHAPTER - 5**

### **MISSION TO INTERNATIONAL POWER PLANTS – IMBIBING NEXT TECHNOLOGIES**

#### **5.1 International Mission**

A mission was taken to the best operating international power plants for imbibing the next technologies. Experts in the field of power plants, power plant operation and maintenance personnel from Indian power plants participated in the mission to international power plants.

In this mission the latest power plants incorporating state of the art technologies, incorporating best operating and maintenance practices have been visited. These power generating units are in Australia, Germany and Japan.

The units visited are given below.

##### **a. Australia**

1. CS Energy Limited, Swanbank power station
2. Tarong Energy

##### **b. Germany**

1. RWE power – Niederaussem power plant
2. STEAG Voerde
3. Mainz Wiesbaden Combined cycle power plant
4. E ON Engineering

##### **c. Japan**

1. Kawagoe Plant of Chubu Electric
2. Hekinan Plant of Chubu Electric

The features of some of the international power generating units and the best practices adopted in operation & maintenance of the plant are highlighted below.

**5.2 RWE power – Niederaussem power plant**

Niederaussem power plant is the single largest lignite fired power generating unit with installed capacity of 1000 MW. **Optimized plant Engineering (BoA)** concepts have been adopted in this plant to achieve the thermal efficiency of 43.2%. The BOA concept combines the best technologies available today for converting lignite into electricity.

In this power plant, raw lignite is combusted in a steam generator, which has a thermal capacity of 2,306 MW. The fuel consumption is 847 tons/hr of raw lignite and the steam generation is about 2663 tons/hr.

**Power plant Performance – Best Design and Operating Practices**

Some of the design and best operating practices adopted in the plant are as below:

1. **BoA concept** – The crucial aspect of the BOA concept is the rise in the operating pressure and temperature of the superheated steam. The operating pressure and temperature of the superheated steam at this plant are 265 / 60 bar and 580 / 600°C respectively.
2. Additional flue gas coolers have been installed to recover as much heat as possible from the flue gases and reduce the flue gas temperature up to 57°C. It is used to preheat the combustion air and the water in the water steam cycle. This improves the operating efficiency of the power generating unit.
3. Improved operating efficiency is also achieved by reducing the condenser pressure. The condenser pressure is maintained at negative pressure of 29 to 35 millibar. This has also been achieved by cooling tower performance improvement.
4. The operating efficiency of the conventional lignite power generating unit is about 35.5%. The plant has achieved an operating efficiency of 43.2% through the following measures:



---

**MISSION TO INTERNATIONAL POWER PLANTS – IMBIBING NEXT TECHNOLOGIES**

---

<b>S no</b>	<b>Improvement measures</b>	<b>% increase in operating efficiency</b>
1	Reduced condenser operating pressure	1.4
2	Waste gas heat utilization	0.9
3	Increase in steam parameters	1.3
4	Process optimization	1.1
5	Improved turbine efficiency	1.7
6	Reduced auxiliary power requirement	1.3
	<b>Total</b>	<b>7.7</b>

Source: RWE website – www.rwe.com

### **Environment aspects**

In the boiler, the flue gases are cleaned in several steps to ensure that statutory emission limits are strictly adhered to and often significantly improved on.

The raw lignite is combusted using pinpointed additions of combustion air, which limits the formation of nitrogen oxide to the permissible levels.

In the flue gas desulphurization system, the flue gas is treated with lime stone slurry to separate the sulphur dioxide. Gypsum has been produced in the desulphurization plant and has been utilized in production of construction materials.

The clean flue gases are discharged into the atmosphere via the cooling tower. Letting out flue gas in the cooling tower is a state of the art technology, which eliminates the construction cost of chimney by design. Also, this results in improved performance of the cooling tower.

The schematic diagram of the lignite fired power station with optimized plant engineering (BoA) is given below.

**Schematic diagram of Lignite fired power generating unit with Optimized Plant Engineering (BoA) concept**

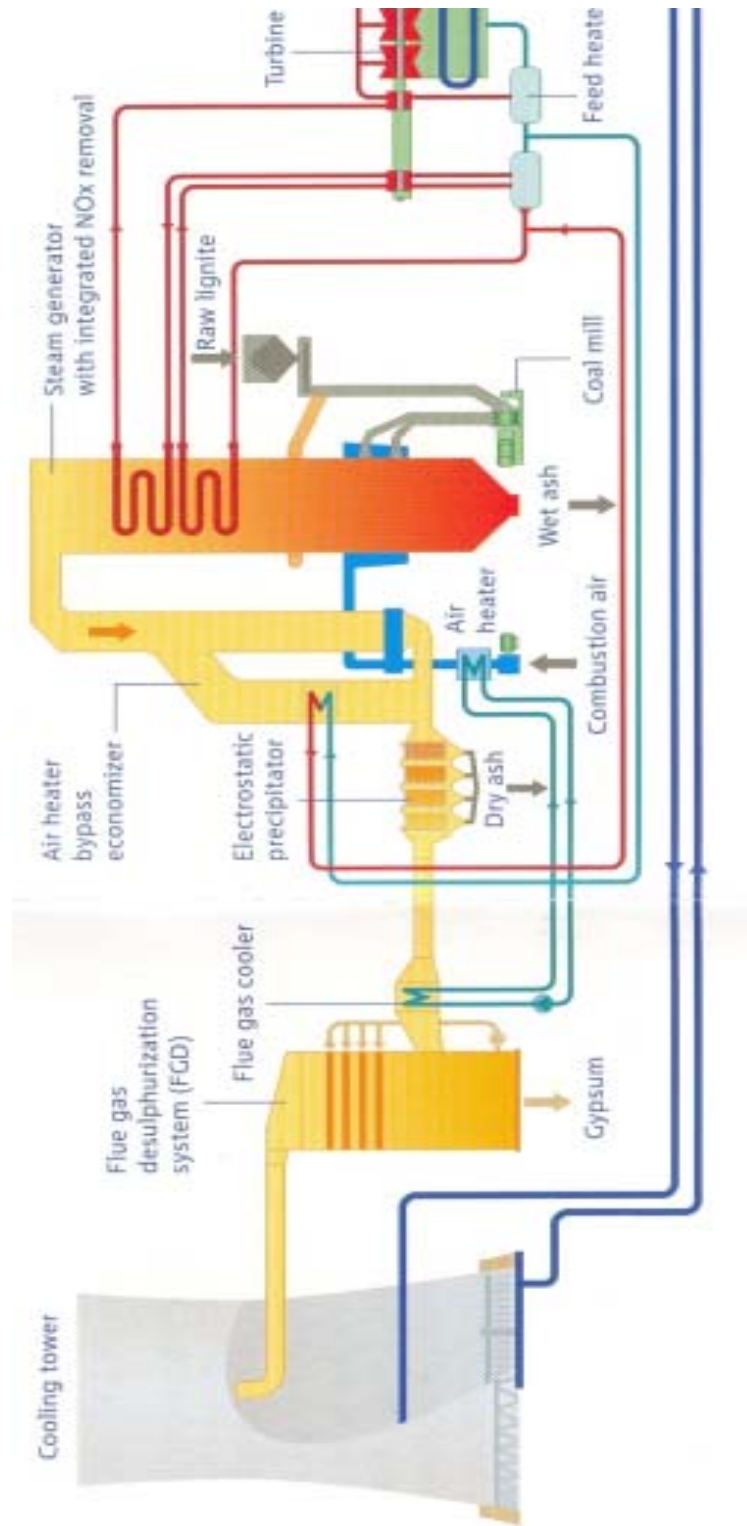

### 5.3 STEAG Voerde Power Plant



STEAG voerde power station has total installed capacity of 2,120 MW. Hard coal has been utilized as fuel.

The total power generation is about 10 billion kWh/yr.

The plant has adopted the latest computerized

management systems for effective operation & maintenance of the power plants and improving the performance of the unit. The following computerized systems have been adopted

1. Energy Management system
2. Plant management system

#### **Energy Management system**

The energy management system evaluates the existing on line measured data and recognizes the potential for optimization by assessing the processes and components.

The system continuously assesses the plant operation, comparing it with the current calculated optimum, so that the unit can be run at maximum efficiency. The energy management system estimates the potential for optimization and even minimal reduction in operating efficiency is identified and pinpointed.

The energy management system is based on a three tiered concept – evaluation, Optimization and forecast for cost relevant power plant sections. All results are evaluated at cost so that the effects of different operating parameters on cost can be directly compared.

The features of the energy management system are:

- Computation of ratios and key figures such as efficiencies, electric energy from cogeneration, start up cost etc
- Component evaluation (steam generator, steam water cycle, condenser, pumps, flue gas circuit etc)
- Optimizing (soot blowing, gas turbine compressor washing etc)
- Fore cast (unit efficiency, maximum unit output etc)

### **Plant Management System**

Integrated plant management system, makes all operating processes rational and transparent right from shift planning to component use. The plant management system helps the plant team to detect weak spots early and optimize operating procedures. In addition it gives up to date information with all organizational, technical & commercial details.

Based on master data and timely operating data acquisition, the plant management system supports the plant team in the following areas of operation:

- Minimizing of the administrative effort invested in plant management
- Efficient job scheduling and control along with performance recording and documentation
- Cost optimized shift planning with integral payroll data acquisition
- Optimizing and reporting of the use of operating supplies and the stocks of supplies
- Daily cost status, availability data and official requirements compliance information
- Assurance of compliance with processing and quality standards
- Subject related control of information flow and authorizations
- Dependable safety disconnection process with conflict check and switch in warning

---

**MISSION TO INTERNATIONAL POWER PLANTS – IMBIBING NEXT TECHNOLOGIES**

---

**5.4 Mainz Wiesbaden Combined cycle power plant**

Mainz Wiesbaden combined cycle power plant has installed capacity of 405 MW. The plant has been designed for base load operation. The plant has a multiple shaft gas turbine. The power output from the gas turbine plant is 276 MW.

The combined cycle power plant has a triple pressure boiler, with a steam turbine of capacity 137 MW. Steam from the combined cycle plant has also been supplied to the near by paper plant and plastic manufacturing unit for meeting the process requirement. The features of the combined cycle power plant are as follows:

- ❖ The original installed capacity of the combined cycle power plant is 385 MW. Capacity augmentation of gas turbine was taken up and incorporation of district heating system have resulted in increase in overall capacity of the combined cycle power plant. After the modifications the plant capacity has increased to 405 MW.
- ❖ The overall operating efficiency of the combined cycle power plant is 58.5%.
- ❖ Gas is received at a pressure of 40-60 bar and then the pressure is reduced to the required pressure of 28 bar. Online gas Chromotograph is available for monitoring the characteristics.
- ❖ Gas preheating system is available for preheating the incoming gas up to 200°C. Boiler feed water has been utilized for preheating the gas. The gas preheating system can also be by passed incase of any leakage in preheating system. The firing in gas turbine does not get affected due to lower gas temperature.
- ❖ The gas preheating system improves the overall cogeneration efficiency. The increase in cogeneration efficiency is to the tune of 0.2-0.3%.
- ❖ Air preheating system is available for preheating the inlet air to the gas turbine. The air preheating system is utilized during winter season, for preheating the air up to 9°C. Feed water is utilized for preheating the air.

- ❖ Online washing for the compressor has been carried out everyday. Without washing the reduction in load is approx 1% and the reduction in operating efficiency is about 0.5%. Offline washing is carried out only during shutdown. DM water is utilized for online washing and the DM water consumption is about 600 lits including the washing solution.

### **5.5 E ON - Engineering**

E ON is one of the largest private energy service providers in the world. E ON Engineering is the main engineering centre for all E ON group companies.

For the power plants E ON engineering provides services for the entire life cycle of the power plants and systems. This include

- Development, modification, dismantling and maintenance projects
- CO<sub>2</sub> and CHP consulting
- Approval management, quality management
- Project, site and commissioning supervision
- Service life and efficiency increasing measures
- Research and development projects
- Quality assurance design, manufacturing and installation
- Failure analysis and material science

E ON Engineering has a division for process optimization. The main objective is to concentrate and focus on the power plant optimization. Efficiency improvement of power plants, measurements and examinations aiming at process optimization and carrying out acceptance test on every plant component were the core competencies of the division.

The process optimization has been taken up for all aspects of the power plant operation. These include the following:

- ❖ Optimization of furnace and boiler systems
  - Milling plants
  - Steam generators

---

**MISSION TO INTERNATIONAL POWER PLANTS – IMBIBING NEXT TECHNOLOGIES**

---

- ❖ Machinery components
- ❖ Performance monitoring systems
- ❖ Mobile process optimization
- ❖ Sound measuring laboratory
- ❖ Calibration laboratory

**Furnace and Boiler optimization**

Optimization of boiler and furnace has been taken up on three major areas:

Fuel – pulverized fuel fineness and distribution. The pulverized fuel fineness and distribution test was carried out using AKOMA fuel sampling system. The AKOMA system works according to the principle of isokinetic sampling using a zero pressure probe.

By using a pendulum it is possible to trace the complete cross sectional area with only one measuring stub per pulverized coal dust line. The schematic of the AKOMA PF dust measuring system is shown below.

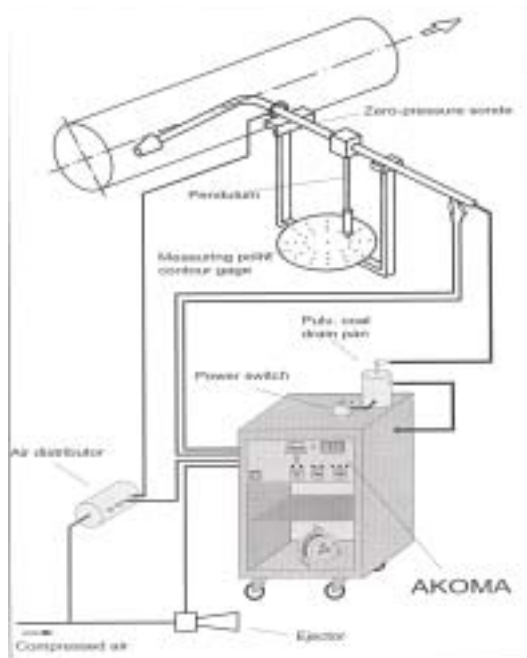

**AKOMA pulverized fuel dust measuring system**

Combustion air – air balancing and air distribution at the burners, burner swirl

Flue gas – optimization of excess air, flue gas analysis on furnace walls and determination of leakage and emissions

### **Mechanical machinery components**

All power plant components are tested in order to evaluate and improve performance, safety and economy of operation. This includes:

- Steam and water turbines
- Pumps
- Fans and compressors
- Heat exchangers
- Cooling towers and
- Other auxiliary plant components

### **Performance monitoring system**

The performance monitoring system continuously assesses the current efficiency of operation in terms of “process quality” defined as the ratio between current unit efficiency and optimum efficiency of operation under the current operating condition.

The optimum efficiency is calculated using proven process calculation software based on reference data obtained during heat consumption tests with calibrated measuring equipment.

Plant components showing deviations to their optimum potential are identified. This gives an opportunity for the plant personnel to take necessary action, improve the operation and efficiency of generation immediately.

The following systems are monitored in a minimum performance monitoring system configuration.

- Water steam cycle
- Cooling water cycle



---

**MISSION TO INTERNATIONAL POWER PLANTS – IMBIBING NEXT TECHNOLOGIES**

---

- Air flue gas system
- Milling plant
- Boiler

**Mobile process optimization**

The mobile process optimization system hardware consists of several individual portable measuring and monitoring modules arranged and customized according to the respective requirements.

The mobile process optimization system consists of portable equipment for PF measurement, flue gas analysis, fly ash measurement, temperature measurement, calibration, thermodynamic examination, sound measurement, flow rate measurement etc.



# CHAPTER - 6

## ACTION PLAN AND CONCLUSION

### 6.1 Action Plan

The proposed action plan for further improving the performance of the individual power generating units in India is given below.

#### 1. Self assessment

- ❖ The individual power generating units have to assess the present performance by utilizing the formats and the guidance given in annexure 1, 2 & 3.
- ❖ After the data collection, allocate the indicative points for all the parameters, as per the recommendations given in the format.
- ❖ These indicative points will help in understanding the present performance status of the power generating units.

#### 2. Target setting

- ❖ Each power generating unit should develop its own individual target for improving all the parameters given in the format.
- ❖ The target figure should be based on the collated best performance parameters.
- ❖ Set and achieve voluntary target of at least 3 to 5 % improvement per year for every parameter.

#### 3. Mass movement for performance improvement in thermal power generating units

A mass movement for performance improvement in thermal power generating units needs to be initiated.

This mass movement will involve all the stake holders of power sector including the power generating units, technology developers, equipment suppliers, consultants, regulatory authorities, government, financial institutions etc.

The activities of mass movement will be centrally coordinated by CII-Sohrabji Godrej Green Business centre.

The movement for performance improvement will be taken up in phases.

**Phase -1**

- ❖ In the first phase of the movement, the chairman of the advisory group of this project will write to the heads of all the power generating units & chairmen of all state electricity boards asking them for volunteering to join the movement.
- ❖ The letter will also seek voluntary target for performance improvement from the individual units.
- ❖ The best practices and the performance improvement projects compiled in this report may be considered for implementation after suitably fine tuning to match with individual power generating unit requirements.
- ❖ If required, CII-Godrej GBC will help the power generating units to improve the performance by providing energy audit services and identifying performance improvement projects specific to the individual power generating units to achieve the targets.
- ❖ The present level of performance and the improvements made by the individual units have to be monitored. CII-Godrej GBC will help the volunteered power generating units in monitoring the performance improvement projects.
- ❖ CII-Godrej GBC will also consolidate the performance improvement projects taken up in the volunteered units and benefits achieved.
- ❖ The performance improvement of these units will be reviewed in the **“Power plant summit”** every year and the information will be disseminated among other Indian power plants.

**Phase - 2**

- ❖ In the second phase, CII-Godrej GBC with the support of experts from advisory and working group of this project will be involved in developing **5 model world Class power plants.**

---

**ACTION PLAN AND CONCLUSION**

---

- ❖ The performance of these model world class power plants will match with the best performance parameters and comparable with the international standards.
- ❖ CII-Godrej GBC will facilitate these units to achieve the world class standards with the time target of 3 years.

**4. Power plant mission**

To convince and demonstrate the feasibility of implementation of the performance improvement projects and also to understand, the latest technologies, the best operating and maintenance practices, it is proposed to take the following missions.

1. Mission to the best performing power plants in India.
2. Mission to the international power plants

The power plants to be visited and the countries needs to be identified.

CII-Godrej GBC will render all possible assistance in making arrangements for the mission.

**6.2 Conclusion**

The objective of the project will be fulfilled only if the performance of all thermal power generating units improves and approaches the world class standards.

In our opinion, the mass movement for performance improvement of thermal power generating units will give additional fillip and facilitate the process of achieving the objective.

The model world class power plants will inspire the other power generating units to join the movement and demonstrate the benefits of achieving the world class standards.

We are sure that the Indian power industry, will make use of this excellent opportunity, improve their performance and move towards the world class standards.

**Annexure – 1****GAS TURBINE & COMBINED CYCLE POWER PLANTS**

**Availability / Reliability (Avg. of last 3 years of operation)** Maximum Score Possible

Planned outages	Hours	720-501	500-361	360-167	<168	7
	Indicative Points	1	3	5	7	

Forced outages	Hours	>265	264-176	175-130	<130	5
	Indicative Points	1	2	3	5	

PAF	%	92-94	94-96	96.1-97.9	> 98	15
	Points	1	2	7	15	

Capacity utilization during peak hours	%	90-96	96-101	101-102	102-105	10
	Points	1	2	5	10	

PLF	%	< 80	80-85	89-90	> 90	15
	Points	0	5	10	15	

**Efficiency (Avg. of last 3 years of operation)**

Heat Rate	% of design	90-94	94-96	96-98	> 98	10
	Indicative Points	10	5	2	1	

**ANNEXURE**

Aux consumption Indicative	%	3.5 – 3.2	3.2 – 3	3.2 – 2.9	< 2.9	5
	1 Points	2	3	5		

(Note : Definition of parameters and calculations are given as part of annexure - 3 )

**Cost (Avg. of last 3 years of operation)**

Cost per Unit S/o [ with levelised fixed cost over a life of 25 years	Rs.	2.0 – 1.8	1.8 – 1.7	1.7 – 1.6	< 1.6	7
	Indicative Points	1	3	5	7	

Mean time between minor insp Indicative	% above OEM reco	8	10	13	15	5
	1 Points	2	3	5		

HGP %of EOH above OEM reco	% above OEM reco	8	10	13	15	2
	Indicative Points	0.5	1.0	1.5	2.0	

Deviation from the mean of tolerance band of temp spread	% beyond mean value	1	2	>5	>10	3
	Indicative Points	3	2.0	1.5	1.0	

## Manual on best practices in Indian Thermal Power Generating Units

### Impact on Environment

#### Emission (Avg. of last 3 years of operation)

NOx	PPM	> 90	90 - 75	75 - 50	< 50
	Indicative Points		1	2	3

5

#### Effluent (Avg. of last 3 years of operation)

Ph	Range of Values	6.51-6.69 8.26-8.49	6.70-6.79 7.76-8.25	6.80-6.89 7.26-7.75	6.90 – 7.25
	Points	0.1	0.3	0.5	1
TSS	% of statue	81-99	66-80	51-65	< = 50
	Points	0.1	0.3	0.5	1
Iron	%	81-99	71-80	61-70	< = 60
	Points	0.1	0.3	0.5	1
BOD	%	30-99	20-29	11-19	< = 4
	Points	0.1	0.3	0.5	1
COD	%	35-99	25-34	16-24	< = 15
	Points	0.1	0.3	0.5	1

5

### Safety for People in Campus

#### Plant (Avg. of last 3 years of operation)

* Interlocks & Trips	Rank	C	B	A
	Points	0.25	0.5	1
* Fire Prevention Points	Rank	C	B	A
	Points	0.25	0.5	1

4

·Defined separately as part of annexure 3

### Human Resource

#### Resource Utilisation (Avg. of last 3 years of operation)

Manpower	No. Per MW	1-0.8	0.79-0.6	0.59-0.4	< 0.4
	Points	0.25	0.5	0.75	1
Water Consumption	M <sup>3</sup> / hr / MW	1.6-1.8	1.3-1.5	1.0-1.2	< 0.9
	Points	0.25	0.5	0.75	1

2

Total 100



**ANNEXURE****Annexure - 2****COAL BASED THERMAL POWER STATIONS****Availability / Reliability of the plant (Avg. of last 3 years of operation)**Maximum  
Score  
Possible

Planned outages	Hours/Year	720-501	500-361	360-169	< 168	7
	Indicative Points	1	3	5	7	

Forced outages	Hours/Year	> 265	264-176	175-130	< 130	5
	Indicative Points	1	2	3	5	

PAF	%	92-94	94-96	96.1-97.9	> 98	15
	Points	1	2	7	15	

Capacity utilization during peak hours	%	90-96	96-101	101-102	102-105	10
	Points	1	2	5	10	

PLF	%	< 80	80-85	85-90	> 90	15
	Points	0	5	10	15	

**Efficiency (Avg. of the last 3 years of operation)**

Heat Rate	% of design	90-94	94-96	96-98	> 98	10
	Indicative Points	10	5	2	1	

(Kcal/Kwhr with moisture corrected bomb calorimeter GCV of coal fired)

**Manual on best practices in Indian Thermal Power Generating Units**

Aux consumption	%	9.5-9.0	8.9-8.5	8.4-8.0	< 8	5
	Indicative Points	1	2	3	5	

(Note : Definition of parameters and calculations are given as part of annexure 3)

**Cost**

Cost per Unit S/o [ with levelised fixed cost over a life of 25 years	Rs.	2.0 – 1.8	1.8 – 1.7	1.7 – 1.6	< 1.6	10
	Indicative Points	1	3	5	10	

**Impact of Environment (Avg. of last 3 years)****Emission**

SPM	% of statute	95-99	94-90	89-80	< 79	6
	Indicative Points	0.5	1	1.5	2.5	
Sox	* % of standard	61-80	41-60	31-40	< 30	
	Indicative Points	0.5	0.75	1.0	1.5	
NOx	* % of standard	82-99	74-82	66-73	< 65	
	Indicative Points	0.25	0.5	0.75	1.0	

\*\* One credit point for having installed NOx monitoring devise and is in working condition.

\* There is an on date no statute in India. The standard mentioned above is of World Bank.

**World Bank Standards** : 0.2 TPD / MW or 100 TPD (whichever is lower)

**NOx**: 1.1 gm/million calorie heat input.

**Effluent (Avg. of last 3 years)**

Ph	Range of Values	6.51-6.69 8.26-8.49	6.70-6.79 7.76-8.25	6.80-6.89 7.26-7.75	6.90 – 7.25
	Points	0.1	0.3	0.5	1
TSS	% of statute	81-99	66-80	51-65	< = 50
	Points	0.1	0.3	0.5	1
Iron	%	81-99	71-80	61-70	< = 60
	Points	0.1	0.3	0.5	1
BOD	%	30-99	20-29	11-19	< = 4
	Points	0.1	0.3	0.5	1
COD	%	35-99	25-34	16-24	< = 15
	Points	0.1	0.3	0.5	1

5

**Ash Utilisation (Avg. of last 3 years)**

Type of Utilisation	For Each % of fly ash produced
Category I	0.05
Category II	0.04
Category III	0.03
Category IV	0.02
Not Utilised	0.00

6

- Category I - Conversion of Value added product  
 Category II - for making roads & embankments  
 Category III - Developing compacted site for scheduled project  
 Category IV - Land Filling

**Safety for People in Campus****Plant**

* Interlocks &- Trips	Rank	C	B	A	} 4
	Points	0.25	0.5	1	
* Fire Prevention	Rank	C	B	A	
	Points	0.25	0.5	1	

\* Defined separately as part of the annexure 3

**Human Resource****Resource Utilisation**

Manpower Points	No. Per MW	1-0.8	0.79-0.6	0.59-0.4	< 0.4	} 2
	0.25	0.5	0.75	1		
Water Consumption	M <sup>3</sup> / hr / MW	1.6-1.8	1.3-1.5	1.0-1.2	< 0.9	} ----- <b>Total 100</b> -----
	Points	0.25	0.5	0.75	1	

\* Per MW of actual avg, power generation in last 3 years

The suggestions for “safety” is as follows : The arithmetic sum however do not add to 04, it is 03.

a. Interlocks & Trips: (Atleast **two** criterion to be met in any grade for accredit )

<b>A</b>	<b>B</b>	<b>C</b>
<ul style="list-style-type: none"> <li>⇒ No trips due to faulty software and hardware of interlock and trip logic system during last three years.</li> </ul>	<ul style="list-style-type: none"> <li>⇒ No trips due to faulty software and hardware of interlock and trip logic systems during last two years.</li> </ul>	<ul style="list-style-type: none"> <li>⇒ No trips due to faulty software and hardware of interlock and trip logic systems during last one year.</li> </ul>
<ul style="list-style-type: none"> <li>⇒ All originally designed interlocks and trip logics in place.</li> </ul>	<ul style="list-style-type: none"> <li>⇒ One less critical interlock or trip logic defeated.</li> </ul>	<ul style="list-style-type: none"> <li>⇒ Two or more less critical interlock or trip logic defeated.</li> </ul>
<ul style="list-style-type: none"> <li>⇒ All interlocks and trip logics checks.</li> </ul>	<ul style="list-style-type: none"> <li>⇒ Only critical interlocks and trip logics checks once a year.</li> </ul>	<ul style="list-style-type: none"> <li>⇒ Only some interlocks and trip logics once a year.</li> </ul>

***Manual on best practices in Indian Thermal Power Generating Units***

---

Fire Prevention: (At least **three** criterion to be met in any grade for accredit )

<b>A</b>	<b>B</b>	<b>C</b>
<ul style="list-style-type: none"> <li>⇒ No trips due to faulty software and hardware of interlock and trip logic system during last three years.</li> </ul>	<ul style="list-style-type: none"> <li>⇒ No trips due to faulty software and hardware of interlock and trip logic systems during last two years.</li> </ul>	<ul style="list-style-type: none"> <li>⇒ No trips due to faulty software and hardware of interlock and trip logic systems during last one year.</li> </ul>
<ul style="list-style-type: none"> <li>⇒ No incident of fire (major and minor) in last three years</li> </ul>	<ul style="list-style-type: none"> <li>⇒ No incident of fire (major and minor) in last two years</li> </ul>	<ul style="list-style-type: none"> <li>⇒ No incident of fire (major and minor) in last one year.</li> </ul>
<ul style="list-style-type: none"> <li>⇒ Weekly records of checks for Diesel driven fire pump</li> </ul>	<ul style="list-style-type: none"> <li>⇒ Weekly records of checks for Diesel driven fire pump</li> </ul>	<ul style="list-style-type: none"> <li>⇒ Weekly records of checks for Diesel driven fire pump</li> </ul>
<ul style="list-style-type: none"> <li>⇒ Religious checking of deluge systems of generator transformers</li> </ul>	<ul style="list-style-type: none"> <li>⇒ Religious checking of deluge systems of generator transformers</li> </ul>	<ul style="list-style-type: none"> <li>⇒ Religious checking of deluge systems of generator transformers</li> </ul>
<ul style="list-style-type: none"> <li>⇒ Smoke detection equipment in readiness.</li> </ul>	<ul style="list-style-type: none"> <li>⇒ Smoke detection equipment in readiness.</li> </ul>	<ul style="list-style-type: none"> <li>⇒ Smoke detection equipment in readiness.</li> </ul>
<ul style="list-style-type: none"> <li>⇒ Regular fire drills by firemen</li> </ul>	<ul style="list-style-type: none"> <li>⇒ Regular fire drills by firemen</li> </ul>	<ul style="list-style-type: none"> <li>⇒ Regular fire drills by firemen</li> </ul>

**Annexure -3****DEFINITION OF PARAMETERS****A. Auxiliary Energy Consumption**

'Auxiliary Energy Consumption' or 'AUX' in relation to a period means the quantum of energy consumed by auxiliary equipment of the generating station and transformer losses within the generating station, and shall be expressed as a percentage of the sum of gross energy generated at the generator terminals of all the units of the generating station.

$$\text{Aux\%} = \frac{\sum_{i=1}^N \left\{ \sum_{k=1}^A (\text{Energy generated})_k - \left( \sum_{m=1}^B (\text{Energy Sent Out})_m \right)_i \right\}}{\sum_{k=1}^A (\text{Energy generated})_k} \times 100$$

Where Energy Generated = Kwh at each Generator Terminal for  $i^{\text{th}}$  period

Energy Sent Out = Kwh at each outgoing feeder from the Power Station for  $i^{\text{th}}$  period

And A = No. of Generators

B = No. of Feeders

N = No. of time periods

**B. Plant Availability Factor:**

'Availability' in relation to a thermal generating station for any period means the average of the daily average declared capacities (DCs) for all the days during that period expressed as a percentage of the installed capacity of the generating station minus actual auxiliary consumption in MW, and shall be computed in accordance with the following formula:

$$\text{PAF \%} = \left[ \frac{\sum_{i=1}^N \text{DC}_i}{\{N \times \text{IC} \times (100 - \text{AUX}_n)\}} \right] \times 100$$

Where,

IC = Installed Capacity of the generating station in MW,

DC = The capability of the generating station to deliver ex-bus electricity in MW declared by such generating station in relation to any period of the day or whole of the day.

DC<sub>i</sub> = Average declared capacity for the i<sup>th</sup> day of the period in MW, where

$$\text{Average Declared Capacity for a day} = \frac{\sum_{k=1}^Z \text{DC}_k}{\{Z \times \text{IC} \times (100 - \text{AUX}_n)\}} \times 10000$$

Where Z = No. of Time period in a day

N = Number of days during the period, and

AUX<sub>n</sub> = Normative Auxiliary Energy Consumption as a percentage of gross generation;

$$\text{PAF\%} = \left[ \sum_{i=1}^N \frac{\text{Calendar hours} - \text{Total Outage hours}}{\text{Calendar hours}} \right] \times 100$$

**OR**

Where,

Calendar hours = Total hours for i<sup>th</sup> period

$$\text{Total outage hours} = \sum_{i=1}^N \text{FO}_i + \sum_{i=1}^N \text{PO}_i + \sum_{i=1}^N \text{PL}_i$$



Where,

$FO_i$  = Full loss of Capacity due to **Forced Outage** for  $i^{\text{th}}$  period

$PO_i$  = Full loss of Capacity due to **Planned Outage** for  $i^{\text{th}}$  period

$PL_i$  = **Partial** loss of Capacity for  $i^{\text{th}}$  period, where

$$PL_i = \sum_{i=1}^N \left( \frac{c}{IC} \right)_i$$

$c$  = Partial loss of Capacity in MW.

$IC$  = Total Installed capacity of the generating station in MW.

$N$  = Number of time periods

#### C. **Planned Outage Hours:**

Time in hours spent for any scheduled maintenance activity calling for desynchronisation of unit for a certain period. Schedule maintenance means Preventive / Predictive / Condition Base / Design Out maintenance activities.

#### D. **Forced Outage Hours:**

Time in hours spent for bringing back the unit on bar subsequent to failure of any plant and / or equipment (including plant/ equipment having signs of failure initiated, combined with high degree of uncertainty towards stable operation) resulting in desynchronisation of unit (either through protection scheme or by any decision).

#### E. **Plant Load factor:**

**Plant Load Factor** or '**PLF**' for a given period, means the total sent out energy during the period, expressed as a percentage of sent out energy corresponding to installed capacity in that period and shall be computed in accordance with the following formula:

$$PLF \% = \left[ \sum_{i=1}^N \{AG \times (100 - AUX_n)\}_i / \{N \times IC \times (100 - AUX_n)\} \right] \times 100$$

**Manual on best practices in Indian Thermal Power Generating Units**

---

Where,

**IC** = Installed Capacity of the generating station in Kw,

**AG<sub>i</sub>** = Actual Generation in Kwh at Generator Terminal for i<sup>th</sup> period,

**N** = Number of time period

**AUX<sub>n</sub>** = **Normative** Auxiliary Energy Consumption as a percentage of gross generation

**AUX<sub>a</sub>** = **Actual** Auxiliary Consumption as a percentage of gross generation for i<sup>th</sup> period

**OR**

**For any period**

$$\text{x 100 PLF \%} = \frac{\text{Energy Generated (Kwh)}}{\text{Installed Capacity (Kw) x Calendar Hour for the period}}$$

Where,

Energy Generated = Total Energy in Kwh delivered at Generator terminal.

Installed capacity = Total installed / derated / rerated capacity of a power generating station.

**F. Heat Rate:**

**Gross Station Heat Rate' or 'GHR'** means the heat energy input in kCal required to generate one kWh of electrical energy at generator terminals.

**For any period**

$$\text{Heat Rate} = \frac{\sum_{i=1}^N (\text{Coal Consumed} \times \text{Heat value of Coal})_i}{\sum_{k=1}^A \text{Gross Units Generated for the period}} \times 100$$

Where,

Heat value = “Moisture corrected” GCV of equilibrated sample of “as fired” coal determined by using a “Bomb Calorimeter”

Where,

“Moisture corrected” means =  $\frac{100 - T_m}{100 - I_m}$

Where,

$T_m$  = Total Moisture in %

$I_m$  = Inherent Moisture in %

Where,

N = No. of days

Coal consumed = Quantity of coal “as fired” in kg during  $i^{\text{th}}$  day.

Gross units generated = Total of Electrical units generated in Kwh at each generator terminal.

A = No. of generators in the power generating station.

#### **Capacity Utilisation in peak period:**

Definition : Total units generated during peak period in respect of Maximum generation that could be achieved as per installed capacity during the same period, expressed as %.

#### **For any period**

$$\text{Capacity Utilisation Factor \%} = \frac{\sum_{i=1}^N (\text{Gross energy generated})_i}{N \times \text{Total Installed Capacity}} \times 100$$

N = No. of time periods in the “Peak Period” (17:00 hrs to 22:00hrs).

**1. Customers****GOOD GOVERNANCE PARAMETERS**

	Need	Methodology	Elements	Rating	Case study
1.1	Customer service (Trends & improvements for 3 to 5 years)	Customer satisfaction Index	Based on customer needs which are predefined		
1.2	Customer service (Trends & improvements for 3 to 5 years)	Customer dis - satisfaction Index	Based on customer needs which are predefined		

**2. Employees**

	Description	Rating	Case study		
2.1	Work Procedures				
2.2	Protections				
2.3	Occupational health hazard				
2.4	Industrial Relationship				
	Need	Methodology	Elements	Rating	Case study
2.5	Increased Productivity achieved through motivated team work (Expressed in terms of cost , Quality & time improvements) Trends: 3 to 5 years	Cross functional teams & No of major issues addressed & effectiveness (results of actions)	Based on customer needs which are predefined Failure analysis. (Lessons learnt) Proactive actions. to avoid failures. Improved Results		

	<b>Need</b>	<b>Methodology</b>	<b>Elements</b>	<b>Rating</b>	<b>Case study</b>
2.6	Manpower	Employee/ MW	Based on total permanent manpower. Additional info on Average contract manpower per day		
2.7	Health & Safety (Trends & improve-ments for 3 to 5 years)	Compliance to Annual Medical checkup	%		
2.8	Health & Safety	Accidents, severity rate & frequency (Based on standard terminology)	Analysis of accidents & steps taken to reduce the same		
2.9	Health & Safety	Mandays lost in O & M areas	Analysis of accidents & steps taken to reduce the same		
2.10	Satisfaction & Engagement (Trends for 3 to 5 years)	Employee satisfaction Index	On 1 to 5 scale - Survey Based on important criteria .		
2.11	Satisfaction & Engagement (Trends for 3 to 5 years)	Absentism Rate	On 1 to 5 scale - Survey Based on important criteria .		

	<b>Need</b>	<b>Methodology</b>	<b>Elements</b>	<b>Rating</b>	<b>Case study</b>
2.12	Satisfaction & Engagement (Trends for 3 to 5 years)	Turnover/ attrition rate	On 1 to 5 scale - Survey Based on important criteria		
2.13	Training & Development . Job enrichment (Trends for 3 to 5 years)	Training mandays	Technical & Managerial skill development.		
2.14	Training & Development / .Job enrichment ( Trends for 3 to 5 years)	Compliance to Training needs identified	Proportion of needs complied with respect to needs identified.		
2.15	Training & Development .Job enrichment (Trends for 3 to 5 years)	Job rotations	Rotation within various depts & divisions .		
2.16	Rewards & recognition	Employees rewarded	Recognition through Annual Appraisal & other forums		
2.17	Rewards & recognition	Plant / unit rewarded	Inland/ overseas agency		
2.18	Effective /Two way communication	No of forums provided	Dept/ divisional meetings		
2.19	Effective /Two way communication	Communication effectiveness	Thro' a survey		

	<b>Need</b>	<b>Methodology</b>	<b>Elements</b>	<b>Rating</b>	<b>Case study</b>
2.20	Code of conduct	Any concerns expressed	Thro' a survey		
2.21	Code of conduct	Litigation faced / pending	Declaration		
2.22	Employee participation	Company/ organisation level and not on unit level	Declaration		

### **3. Society around**

		<b>Rating</b>		<b>Case study</b>
<u>3.1</u>	<u>Hazard management systems</u>			
3.2	Accountability			
3.3	Society	Regulatory compliance		
3.4	Community initiative	No. of community initiative		
3.5	Community initiative	Benefits to society		
3.6	Sharing/Service through professional bodies representing power industry.	Contribution to industry & professional bodies		

		<b>Rating</b>		<b>Case study</b>
3.7	Sharing/Service through professional bodies representing power industry.	Contribution to Educational Institutes		

#### **4. Shareholders**

4.1	Share Holders (or else those who have a stake in cos.)	Meeting share-holders expectations  (Trends & improvements for 3 to 5 years)		
4.2	Share Holders (or else those who have a stake in cos.)	Meeting share-holders expectations  (Trends & improvements for 3 to 5 years)		

#### **5. Suppliers**

5.1	Mutual Benefits through supplier partnership	Frequency.of review Meetings & commitments made/honoured		
5.2	Mutual Benefits through supplier partnership	Satisfaction index		



## 6. Cost / Productivity / Quality

		<b>Rating</b>		<b>Case study</b>
6.1	Cost Control	Conformance to Capital Budget Plan		
6.2	Cost Control	Conformance to O&M Budget Plan		
6.3	Increased productivity	Cost reduction projects undertaken & savings achieved per year		
6.4	Increased productivity	Quality improvement projects undertaken & savings achieved per year		
6.5	Increased productivity	No of cycle time reduction projects undertaken & results		
6.6	Quality	Increased productivity		

### Rating System

1. Parameter not monitored	-	0
2. Parameter being monitored	-	1
3. System in place for monitoring / control	-	2
4. Consistency in following systems	-	3
5. Continuous improvement in systems & parameters	-	4
6. Benchmarking of parameters	-	5
For example, customer satisfaction		
If plant doesn't know customer is satisfied / not	-	0
If plant is monitoring the customer satisfaction	-	1
If there is a system in place (meeting / feedback on a regular basis)	-	2
If the system is followed on a continual basis till date	-	3
Marked improvement in customer satisfaction recorded with innovative parameters in subsequent meeting / feedback	-	4
Benchmarking with known & successful entity (national/international)	-	5